

VCM Vertical Inline Process Pump



Single Stage Vertical Centrifugal
Pumps for General Service,
Petroleum and Petrochemical
Applications.

VCM-0000

September 1, 1999



GENERAL DESCRIPTION

VCM - an advanced design Single Stage Vertical In-Line Centrifugal Pump with exceptional flexibility and versatility to meet the requirements of a wide variety of pumping applications. The unit is ruggedly designed for minimum maintenance and to meet the heavy-duty requirements of continuous duty operation of general industry.

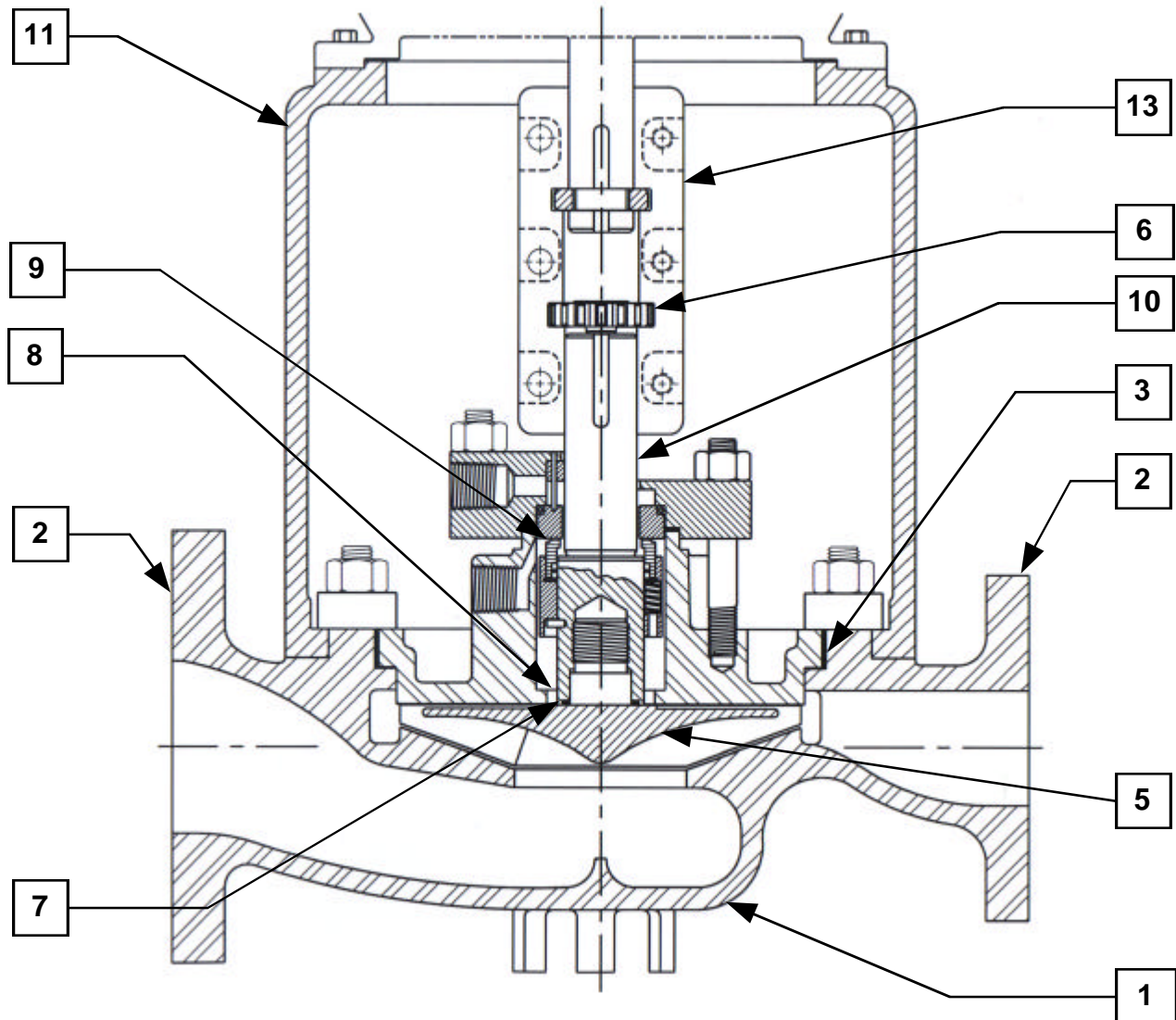

STANDARD FEATURES

1 Pump Casing:

In-line mounted casings for ease of installation and service.

2 Flanges:

150 lb. FF per ANSI B16.5 standards. 150# R.F. and 300# R.F. available.

3 Casing / Cover:

Casing to Cover register fit is achieved by a unique Teflon locating ring eliminating corrosion at the fit. A fully confined compression gasket ensures proper sealing and alignment. Non-asbestos compressed sheet gasket is standard. Other materials available to suit application.



Model VCM Centrifugal Pump

4 Casing Drain: (not shown)

Casing can be completely drained. Drain valves optional.

5 Impeller:

Open, single suction impeller. Impellers are precision cast for higher efficiencies, low vibration and smooth, trouble free operation.

6 Impeller Adjusting Stud:

Innovative adjustment stud offers a micrometer-type adjustment to control impeller running clearance. No need for feeler gauges.

7 Throat Bushing:

Close clearance carbon Throat Bushing helps provide optimum seal chamber environment. Not required on plan13 flush.

8 Mechanical Seal:

Available with reliable, low cost shaft mounted mechanical seals or cartridge type mechanical seals for precise seal face setting and ease of maintenance. Stainless gland plate is standard.

9 Seal Chamber:

Accepts all mechanical seal arrangements. Sealing system computer-aided design and close coordination with seal manufacturers ensures optimum seal chamber environment.

Seals can be removed without disturbing the Driver.

10 Shaft Arrangement:

Group I and II VCM's use a solid 316 SS shaft without a shaft sleeve. This design feature allows complete replacement at less cost than a shaft with sleeve. It also provides maximum shaft stiffness.

11 Motor Support Housing:

Heavy Duty Motor Support with register fits at the Casing Cover and Driver for precise alignment.

12 Soleplate: (not shown)

Optional soleplate provides increased mounting support.

13 Coupling:

Two piece, stainless steel rigid coupling provides accurate shaft alignment and ensures repeatability of shaft runout.

Operating Range Chart for 60 Hertz Drivers

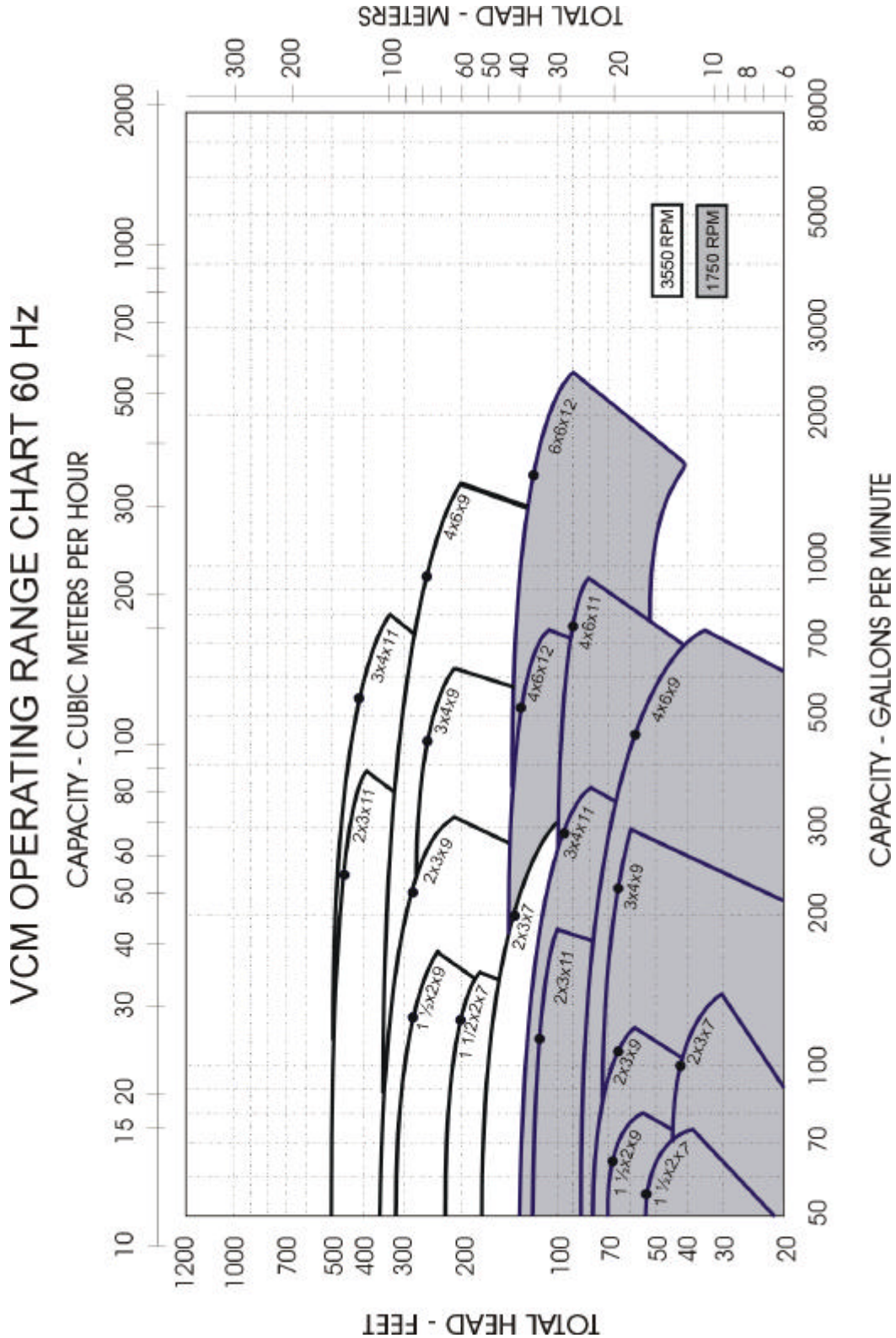

Model VCM Centrifugal Pump

Cross Sectional Details

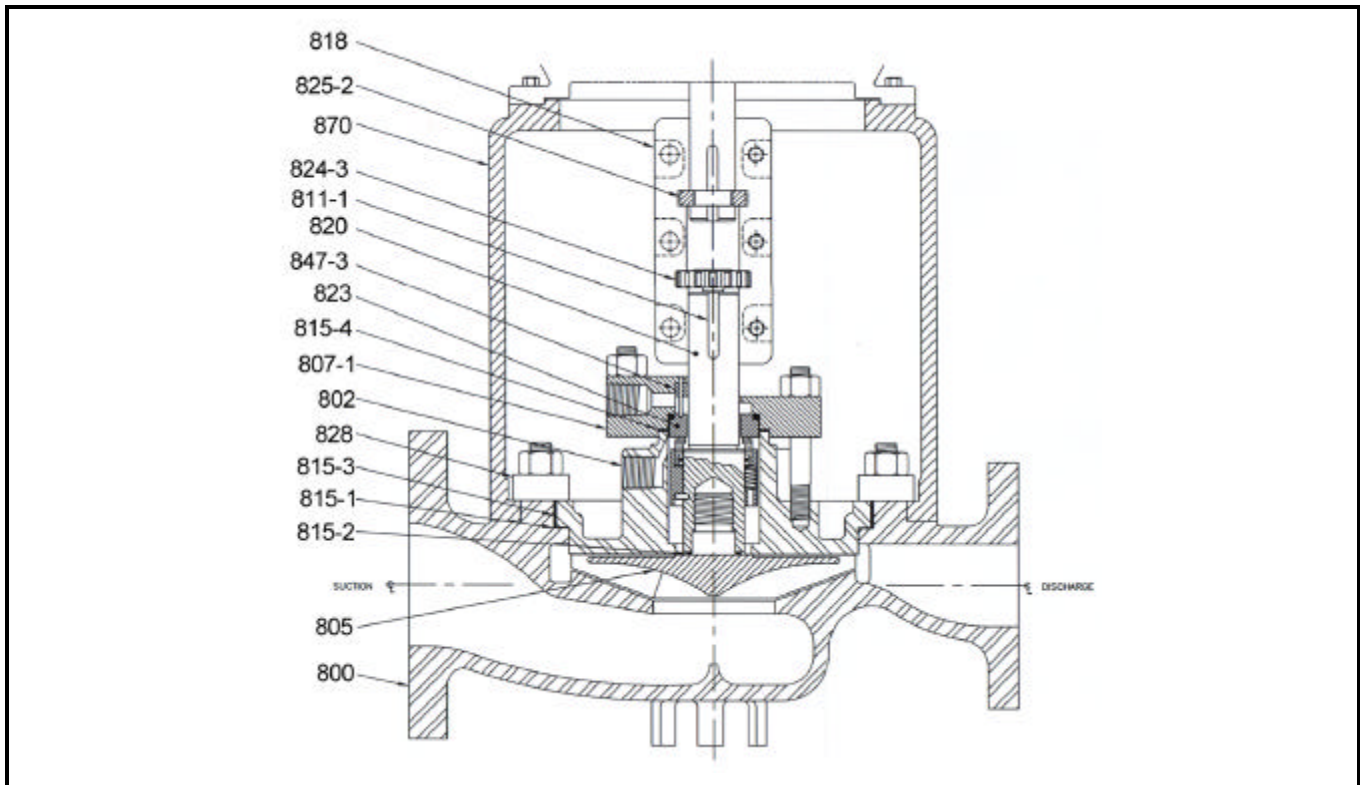

Part Number	Description	TYPE II	TYPE V
800	Casing	A216 WCB Steel (B44400)	A351 CF8M 316 SS (D11200)
802	Casing Cover	A216 WCB Steel (B44400)	A351 CF8M 316 SS (D11200)
805	Impeller	A743 CF8M 316 SS (D12200)	A743 CF8M 316 SS (D12200)
807-1	Mechanical Seal Gland	A276 316 316 SS (D21400)	A276 316 316 SS (D21400)
811-1	Key - Coupling	Steel	Steel
815-1	Casing Gasket	Non-Asbestos Compressed Sheet	Non-Asbestos Compressed Sheet
815-2	Impeller "O" Ring	Teflon (T50200)	Teflon (T50200)
815-3	Casing Cover Ring	Teflon (T50200)	Teflon (T50200)
815-4	Seal Gland Gasket	Non-Asbestos Compressed Sheet	Non-Asbestos Compressed Sheet
818	Coupling - Rigid Spacer Type	A743 CF16F 316 SS (D12601)	A743 CF16F 316 SS (D12601)
820	Shaft	A276 TP 316 A 316 SS (D21400)	A276 TP 316 A 316 SS (D21400)
823	Mechanical Seal Assembly	As Specified	As Specified
824	Adjusting Stud	A743 CF16F 316 SS (D12600)	A743 CF16F 316 SS (D12600)
825-2	Locating Ring	Steel	Steel
828	Casing Cover Clamp	303 SS (D22800)	303 SS (D22800)
847-3	Throttle Bushing	Carbon (U21100)	Carbon (U21100)
870	Motor Support	Cast or Ductile Iron	Cast or Ductile Iron

Other alloys available. Including, but not limited to: Alloy 20, Hastelloy B, Hastelloy C, Monel, and Duplex stainless steel.

Maximum Allowable Nozzle Loading - Side Suction / Side Discharge

Both users and manufacturers are concerned with the amount of pipe loads a Centrifugal Pump can withstand without affecting its operation.

The customer would, of course, be most pleased if Centrifugal Pumps would withstand unlimited pipe strains. As manufacturers, *we would like to see no external forces acting on our pumps at all.*

The following chart gives the maximum permissible Forces (F) and Moments (M) and their Resultants on the Pump based on Pump Suction and Discharge Nozzle (Flange) Sizes.

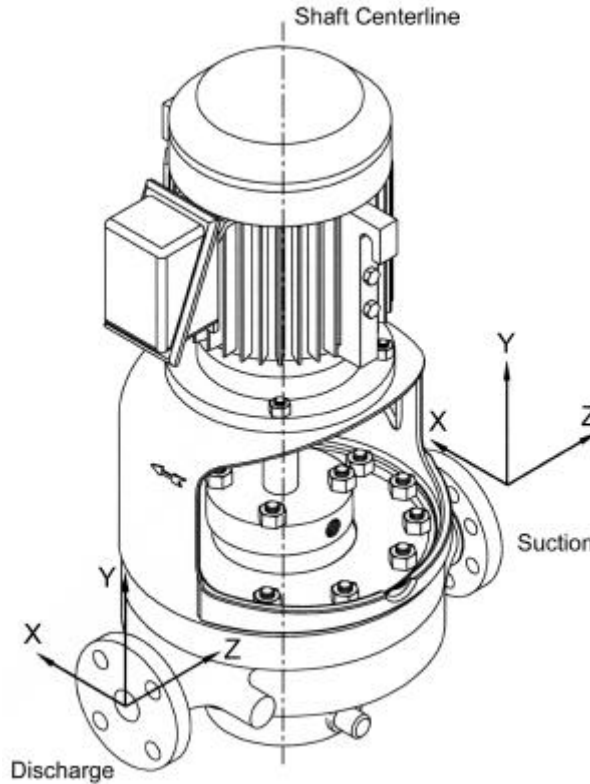

Caution:

Should these limits be exceeded a malfunction and shorter life of Pump may result.

U.S. Customary Units

Nominal Flange Size (Inches)							
Force / Moment	1-1/2	2	3	4	6		
Suction and Discharge Nozzle Connections							
FX	40	80	120	160	280		
FY	50	65	100	130	230		
FZ	35	100	150	200	350		
FR	73	144	217	287	504		
Suction and Discharge Nozzle Connections							
MX	85	170	350	490	850		
MY	65	130	265	370	650		
MZ	45	85	175	250	435		
MR	116	230	473	663	1155		

Note:

- 1.) The above values apply to Carbon Steel and Stainless Steel Pump construction. Consult David Brown Union Pumps Company for other Materials of Construction.
- 2.) Each value above indicates a range from minus to plus of that value; i.e. 160 indicates a range from -160 to +160.
- 3.) F = Force in Pounds; M = Moment in Foot Pounds; and R = Resultant.
- 4.) X , Y , and Z = Orientation of Nozzle (Flange) Loads, see illustration above.
- 5.) Coordinate system has been changed from API-610, 7th Edition Standard, conversion to ISO 1503 convention.



Model VCM Centrifugal Pump

Pump and Driver Outline Drawing - U.S. Customary Units

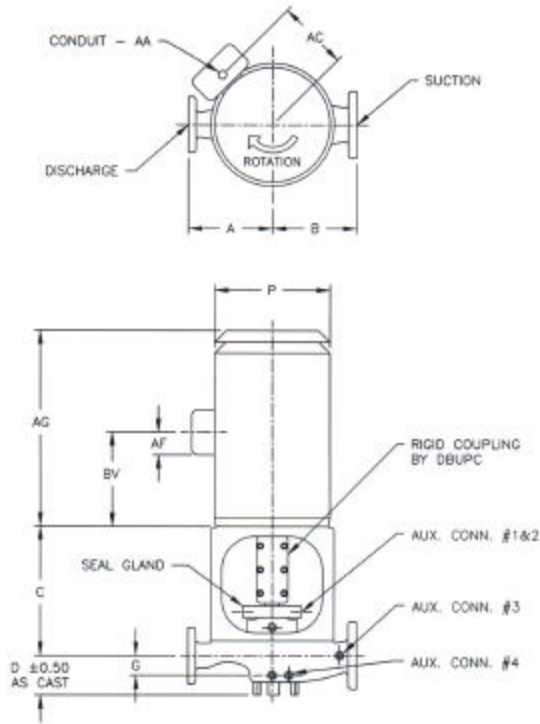

THIS DRAWING IS NOT INTENDED TO REPLACE FACTORY PRODUCED CERTIFIED DRAWING. PLEASE RESERVE COMMENTS FOR FACTORY PRODUCED CERTIFIED DRAWING WHICH WILL REFLECT DETAILS REQUIRED BY SPECIFICATIONS.

DO NOT USE FOR CONSTRUCTION UNLESS CERTIFIED

NOTES:

- 1.) Dimensions are in inches.
- 2.) Dimensions of pump are $\pm 0.12"$ unless otherwise noted.
- 3.) Dimensions of Auxiliary Systems $\pm 1.00"$ unless otherwise noted.
- 4.) Locations of Piping Components may vary.
- 5.) Pump flange ratings based on ANSI B16.5 300# Raised Face flanges.
- 6.) Dimensional tolerances of motor are in compliance with NEMA MG 1.

Pump Size	Weight - Lbs.	A	B	D	G	Driver Information		
1-1/2 x 2 x 7	115	7.50	7.50	3.50	1.75	Mfgr.:		
2 x 3 x 7	130	7.50	7.50	3.75	2.00	Frame: Enclosure:		
1-1/2 x 2 x 9	135	8.50	8.50	3.88	2.125	Horsepower: Weight:		
2 x 3 x 9	180	8.50	8.50	4.0	2.25	Motor "AG" Dim. Max.:		
3 x 4 x 9	220	11.0	11.0	4.50	2.75	Motor Volts / Phase / Hertz:		
4 x 6 x 9	265	12.0	12.0	7.50	4.50	See Motor Print for additional dimensions and information.		
2 x 3 x 11	235	10.0	10.0	4.50	2.875	Mechanical Seal Information		
3 x 4 x 11	280	12.0	12.0	4.75	3.00	Mfgr:		
4 x 6 x 11	360	14.0	14.0	5.50	2.75	Type:		
4 x 6 x 12	600	14.0	16.0	8.0	3.75	Code:		
6 x 6 x 12	690	16.0	18.0	8.0	5.75	Size:		
CERTIFIED CORRECT FOR THE FOLLOWING:						Auxiliary Pump Connections		
Contractor:					No.	Size	Type	Connection
User:					1	1/2"	NPT	Mech. Seal - IN- API Plan
Location:					2	1/2"	NPT	Seal Gland Vent/Drain- Plugged Opposite Side
Service:					3	1/2"		Disch. Conn. - Flush Supply API Plan -
Customer P.O.:			Item No.:					
Item No.:			Pump S/N:		4	1/2"		Casing Drain -
Certified By:			Date:					

UNICHEM

features unique service advantages...

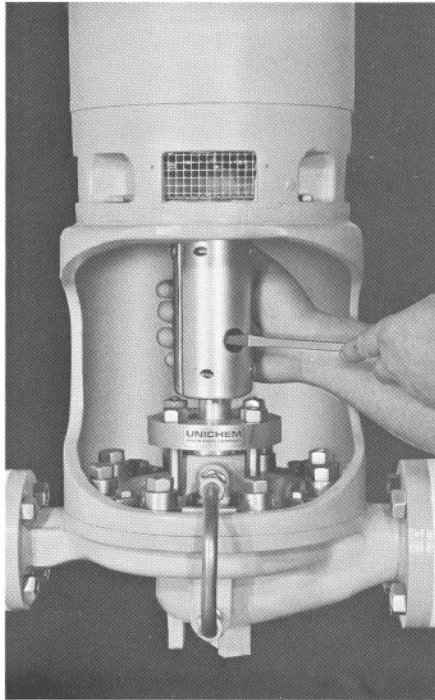

Adjusting Running Clearance

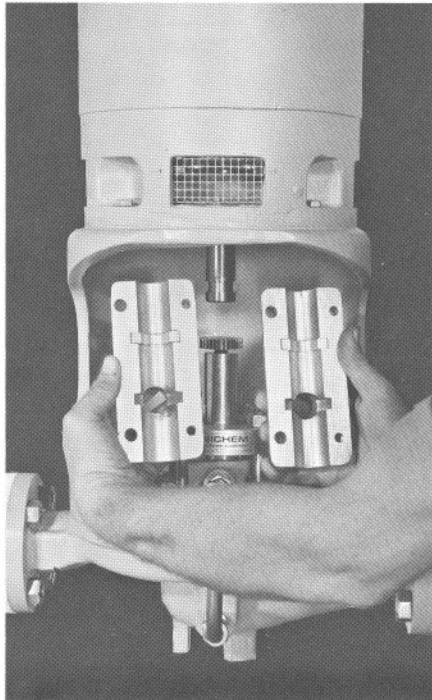

Rigid Coupling Removed

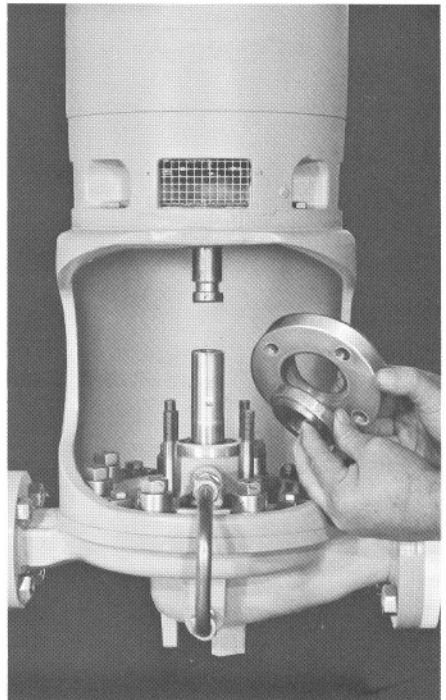

Removing Seal Gland

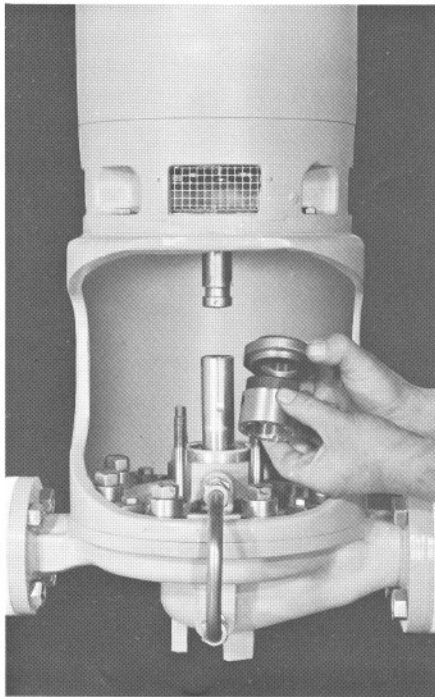

Seal Element Removed

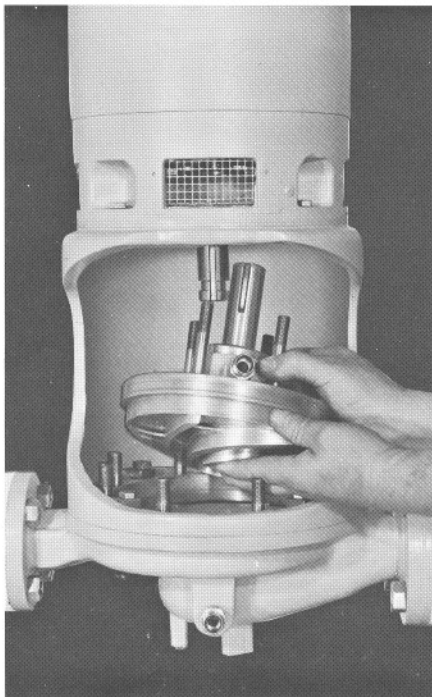

Removing Rotating Element

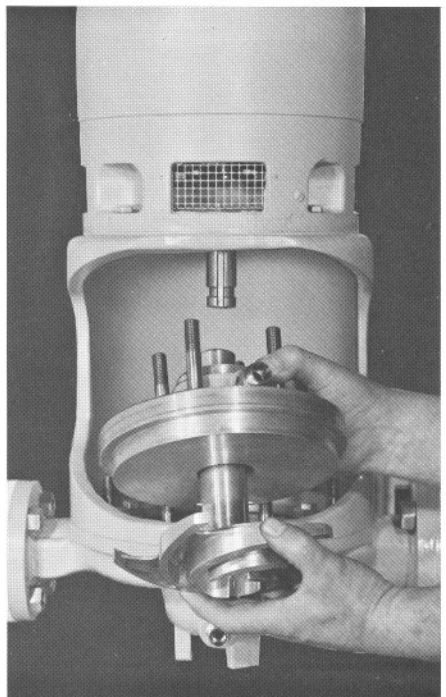

Servicing Rotating Element

As the pictures indicate, the rigid coupling, gland and seal cover and **rotating element** are removed without the use of special tools . . . **The impeller and shaft simply drop out of the cover for inspection or change out.**