

Universal I Series

ROTARY POSITIVE DISPLACEMENT PUMP

FORM NO.: 95-03002 REVISION: 02/2014

READ AND UNDERSTAND THIS MANUAL PRIOR TO OPERATING OR SERVICING THIS PRODUCT.



SPX FLOW, Inc.
611 Sugar Creek Road
Delavan, WI 53115 USA

Tel: (800) 252-5200 or (262) 728-1900
Fax: (800) 252-5012 or (262) 728-4904

E-mail: wcb@spxflow.com
Web site: www.spxflow.com

Information contained in this manual is subject to change without notice and does not represent a commitment on the part of SPX FLOW, Inc. No part of this manual may be reproduced or transmitted in any form or by any means, electronic or mechanical, including photocopying and recording, for any purpose, without the express written permission of SPX FLOW, Inc.

Copyright © 2015 SPX FLOW, Inc.
All Rights Reserved.

Revision Date: 02/2014

Publication: 95-03002

Warranty	6
Shipping Damage or Loss	6
Warranty Claim	6
Safety	7
Replacement Labels	8
Application Instructions	8
Care of Stainless Steel	9
Stainless Steel Corrosion	9
Alloy 88	9
Elastomer Seal Replacement Following Passivation	9
Introduction	10
Pump Receiving	10
Pump Characteristics	10
Equipment Serial Number	10
Pump Shaft Location	10
Operating Parameters	11
Factory Remanufacturing Program	12
Installation	13
Install Pump and Drive Unit	13
Install Connections and Piping	14
Install Check Valves	15
Install Isolation Valves	15
Install Relief Valves	15
Inlet Side Strainers and Traps	16
Install Pressure Gauges	16
Check Coupling Alignment	16
Check Angular Alignment	17
Check Parallel Alignment	17
Check Belt and Chain Drive Alignment	17
Check Pump Rotation	18
Operation	19
Pre-Startup Checklist	19
Startup Procedure	19
Shutdown Procedure	19
Emergency Shutdown Procedure	19
Maintenance	20
Important Safety Information	20
Lubrication	20
Maintenance Inspections	21
Maintenance Inspection Chart	23
Annual Maintenance	24
Cleaning	24
Fluid Head Disassembly (All Models)	25
Model 320 and 324 Body Disassembly	26
Model 323 Aseptic Body Disassembly	26
Seal Maintenance	27
Gear Case Disassembly	33
Shaft Assembly	35
Gear Case Assembly	37
Fluid Head Assembly	44
Jacketed Cover	47

Reference Tables	48
Parts Lists	50
006-014-015-018-024-UI Pump Parts	50
006-014-015-018-024-UI Common Parts	52
030-033A-034-040-UI Pump Parts	56
030-033A-034-040-UI Common Parts	58
060-064-130-134-133A-UI Pump Parts	64
060-064-130-134-133A-UI Common Parts	66
220-223A-224-UI Pump Parts	70
220-223A-224-UI Common Parts	72
Universal I PD Pump Vented Covers	77
320-323A-324-UI Pump Parts	78
320-323A-324-UI Common Parts	80
PD Pump Seals Model 006-014-015-018-024-030-034-040-UI	84
PD Pump Seals Model 060-064-130-133A-134-220-223A-224-UI	86
PD Pump Seals Model 320-323A-324-UI	88
Tru-Fit™ Universal I PD Pumps Parts List	90
Grease Seal, Bearing Retainer, O-Ring Seal Carrier Part Number Reference	91
Special Tools	91
Pump Dimensions	92
Universal I PD Pump Dimensions	92
Universal I PD Pump Dimensions - Rectangular Flange with Pedestal	94
Tru-Fit™ Universal I PD Pump Dimensions	96
Troubleshooting	98
Universal I Maintenance Summary Reference Sheet	102
Universal I Maintenance Summary Reference Sheet - Copy for optional removal	103

Warranty

Seller warrants its products to be free from defect in materials and workmanship for a period of one (1) year from the date of shipment. This warranty shall not apply to products which require repair or replacement due to normal wear and tear or to products which are subjected to accident, misuse or improper maintenance. This warranty extends only to the original Buyer. Products manufactured by others but furnished by Seller are exempted from this warranty and are limited to the original manufacturer's warranty.

Seller's sole obligation under this warranty shall be to repair or replace any products that Seller determines, in its discretion, to be defective. Seller reserves the right either to inspect the products in the field or to request their prepaid return to Seller. Seller shall not be responsible for any transportation charges, duty, taxes, freight, labor or other costs. The cost of removing and/or installing products which have been repaired or replaced shall be at Buyer's expense.

Seller expressly disclaims all other warranties, express or implied, including without limitation any warranty of merchantability of fitness for a particular purpose. The foregoing sets forth Seller's entire and exclusive liability, and Buyer's exclusive and sole remedy, for any claim of damages in connection with the sale of products. In no event shall Seller be liable for any special consequential incidental or indirect damages (including without limitation attorney's fees and expenses), nor shall Seller be liable for any loss of profit or material arising out of or relating to the sale or operation of the products based on contract, tort (including negligence), strict liability or otherwise.

Shipping Damage or Loss

If equipment is damaged or lost in transit, file a claim at once with the delivering carrier. The carrier has signed the Bill of Lading acknowledging that the shipment has been received from WCB in good condition. WCB is not responsible for the collection of claims or replacement of materials due to transit shortages or damages.

Warranty Claim

Warranty claims must have a **Returned Goods Authorization (RGA)** from the Seller before returns will be accepted.

Claims for shortages or other errors, exclusive of transit shortages or damages, must be made in writing to Seller within ten (10) days after delivery. Failure to give such notice shall constitute acceptance and waiver of all such claims by Buyer.

Safety

READ AND UNDERSTAND THIS MANUAL PRIOR TO INSTALLING, OPERATING OR SERVICING THIS EQUIPMENT

Waukesha Cherry-Burrell recommends users of our equipment and designs follow the latest Industrial Safety Standards. At a minimum, these should include the industrial safety requirements established by:

1. Occupational Safety and Health Administration (OSHA), Title 29 of the CFR Section 1910.212- General Requirements for all Machines
2. National Fire Protection Association, ANSI/NFPA 79
ANSI/NFPA 79- Electrical Standards for Industrial Machinery
3. National Electrical Code, ANSI/NFPA 70
ANSI/NFPA 70- National Electrical Code
ANSI/NFPA 70E- Electrical Safety Requirement for Employee Workplaces
4. American National Standards Institute, Section B11

Attention: Servicing energized industrial equipment can be hazardous. Severe injury or death can result from electrical shock, burn, or unintended actuation of controlled equipment. Recommended practice is to disconnect and lockout industrial equipment from power sources, and release stored energy, if present. Refer to the National Fire Protection Association Standard No. NFPA70E, Part II and (as applicable) OSHA rules for Control of Hazardous Energy Sources (Lockout-Tagout) and OSHA Electrical Safety Related Work Practices, including procedural requirements for:

- Lockout-tagout
- Personnel qualifications and training requirements
- When it is not feasible to de-energize and lockout-tagout electrical circuits and equipment before working on or near exposed circuit parts

Locking and Interlocking Devices: These devices should be checked for proper working condition and capability of performing their intended functions. Make replacements only with the original manufacturer's renewal parts or kits. Adjust or repair in accordance with the manufacturer's instructions.

Periodic Inspection: Industrial equipment should be inspected periodically. Inspection intervals should be based on environmental and operating conditions and adjusted as indicated by experience. At a minimum, an initial inspection within 3 to 4 months after installation is recommended. Inspection of the electrical control systems should meet the recommendations as specified in the National Electrical Manufacturers Association (NEMA) Standard No. ICS 1.3, Preventative Maintenance of Industrial Control and Systems Equipment, for the general guidelines for setting-up a periodic maintenance program.

Replacement Equipment: Use only replacement parts and devices recommended by the manufacturer to maintain the integrity of the equipment. Make sure the parts are properly matched to the equipment series, model, serial number, and revision level of the equipment.

Warnings and cautions are provided in this manual to help avoid serious injury and/or possible damage to equipment:



DANGER: marked with a stop sign.
Immediate hazards which **WILL** result in severe personal injury or death.



WARNING: marked with a warning triangle.
Hazards or unsafe practices which **COULD** result in severe personal injury or death.



CAUTION: marked with a warning triangle.
Hazards or unsafe practices which **COULD** result in minor personal injury or product or property damage.

Replacement Labels

WARNING: The following labels are installed on your equipment. If these labels are removed or become unreadable, contact your local distributor and they will be supplied at no charge. Refer to "Parts Lists" starting on page 50 for replacement part numbers.

Application Instructions

Apply to a clean, dry surface. Remove the backing from the label, place it in proper position, protect it with a cover sheet and burnish it. (A soft rubber roller also may be used to press the label into place.) Apply all labels to be readable from the front of the pump.

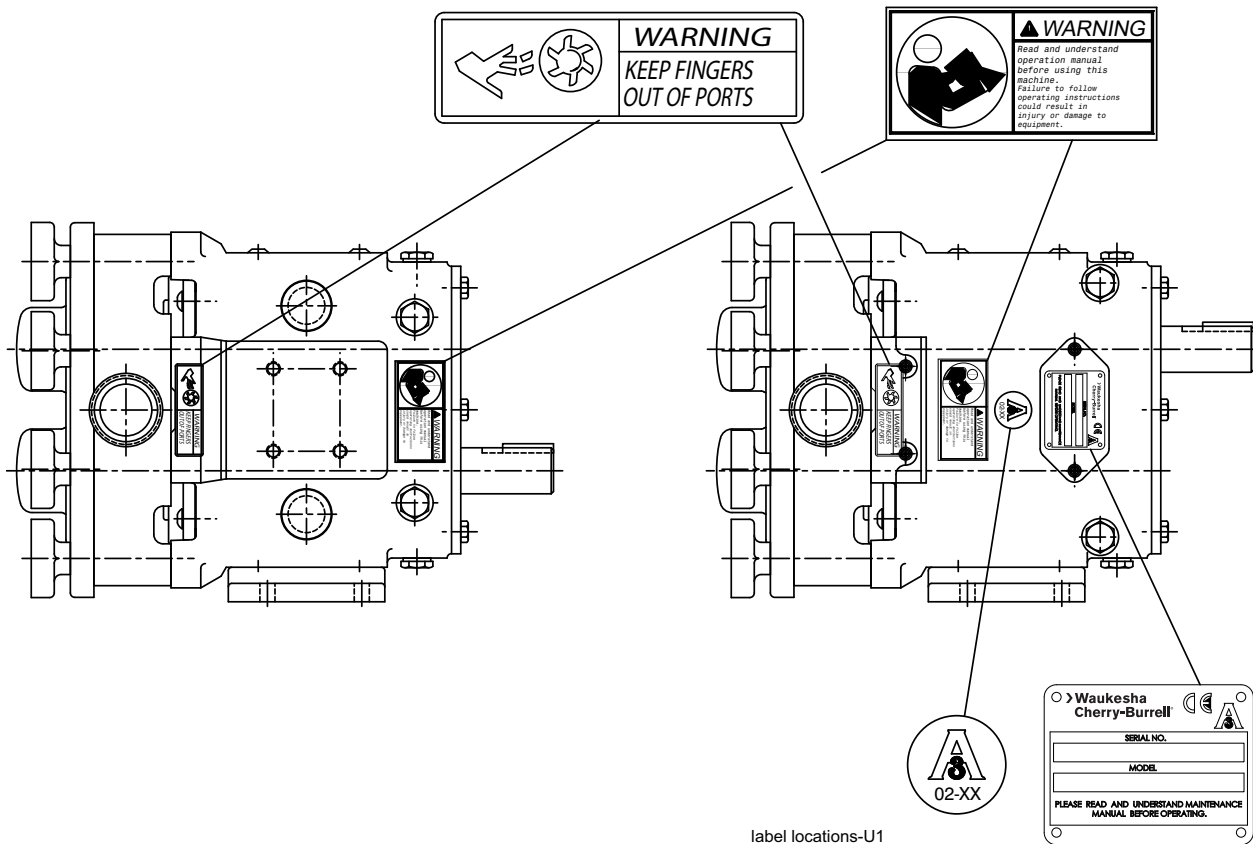

IMPORTANT

1. Pump and Drive are factory aligned.
2. Recheck alignment after installation and before start-up.
3. Recheck alignment periodically, to maximize service life.

33-95

IMPORTANT

To avoid damage to the shaft seals and/or pump parts:

DO NOT START this pump unless Seal Flush has been installed and is turned ON.

PD100-236a

Care of Stainless Steel

Stainless Steel Corrosion

Corrosion resistance is greatest when a layer of oxide film is formed on the surface of stainless steel. If film is disturbed or destroyed, stainless steel becomes much less resistant to corrosion and may rust, pit or crack. Corrosion pitting, rusting and stress cracks may occur due to chemical attack. Use only cleaning chemicals specified by a reputable chemical manufacturer for use with 300 series stainless steel. Do not use excessive concentrations, temperatures or exposure times. Avoid contact with highly corrosive acids such as hydrofluoric, hydrochloric or sulfuric. Also avoid prolonged contact with chloride-containing chemicals, especially in presence of acid. If chlorine-based sanitizers are used, such as sodium hypochlorite (bleach), do not exceed concentrations of 150 ppm available chlorine, do not exceed contact time of 20 minutes, and do not exceed temperatures of 104°F (40°C).

Corrosion discoloration, deposits or pitting may occur under product deposits or under gaskets. Keep surfaces clean, including those under gaskets or in grooves or tight corners. Clean immediately after use. Do not allow equipment to set idle, exposed to air with accumulated foreign material on the surface.

Corrosion pitting may occur when stray electrical currents come in contact with moist stainless steel. Ensure all electrical devices connected to the equipment are correctly grounded.

Alloy 88

Waukesha Alloy 88 is the standard rotor material for Universal I, Universal II, Universal Lobe, Universal 420/520 and 5000 Series Rotary PD pumps. This alloy was developed specifically for corrosion resistance and close operating clearance requirements of high performance rotary positive displacement pumps. Alloy 88 is a nickel based, corrosion-resistant, non-galling or seizing material. The ASTM designation is A494 Grade CY5SnBiM (UNS N26055), and the material is listed in the 3-A Sanitary Standards as acceptable for product contact surfaces.

The above properties make Alloy 88 the ideal material for Waukesha stainless steel PD pumps. The non-galling rotors permit close operating clearances in the liquid end. This provides low slip and minimum shear damage. The rotors will not gall or seize if they come in contact with the body or cover during operation.

The corrosion resistance of Alloy 88 is approximately equal to AISI 300 Series Stainless Steel. However, Alloy 88 has limited resistance to certain aggressive chemicals that may be commonly used in contact with AISI 300 Series Stainless Steel.

Do not use Alloy 88 in contact with nitric acid. Nitric acid is commonly used to passivate new installations of stainless steel equipment. Do not allow nitric acid based passivation chemicals to contact Alloy 88 rotors. Remove the rotors during passivation and use a separate pump to circulate the passivation chemicals. Also, if nitric acid-based CIP cleaning chemicals are used, remove the rotors prior to CIP cleaning and clean them separately by hand in a mild detergent.

If you have questions regarding other aggressive chemicals, please contact Waukesha Cherry-Burrell Application Engineering for assistance.

Elastomer Seal Replacement Following Passivation

Passivation chemicals can damage product contact areas of WCB equipment. Elastomers (rubber components) are most likely to be affected. Always inspect all elastomer seals after passivation is completed. Replace any seals showing signs of chemical attack. Indications may include swelling, cracks, loss of elasticity or any other noticeable changes when compared with new components.

Introduction

Pump Receiving



DANGER: The pump contains internal moving parts. DO NOT put hands or fingers into the pump body ports or drive area at any time during operation. To avoid serious injury, DO NOT install, clean, service, or repair the pump unless all power is off and locked out.

All ports are covered at the factory to keep out foreign objects during transit. If covers are missing or damaged, remove the pump cover for a thorough inspection of the fluid head. Be sure that the pumping head is clean and free of foreign material before rotating the shaft.

Each Waukesha Cherry-Burrell pump is shipped completely assembled, lubricated and ready for use. Review "Operation" on page 19 before operating the pump.

Pump Characteristics

Waukesha Cherry-Burrell Universal I pumps are positive-displacement, low-slip, stainless steel pumps designed with larger diameter shafts for greater strength and stiffness, mounted on a heavy-duty cast iron bearing frame (stainless steel option available) with double-tapered roller bearings.

- Up to 200 psi (13.8 bar) pressure capability.
- No bearings in the product zone.
- Heavy-duty bearing frame with large diameter shafts.
- Greased lubed bearings for positive lubrication to all bearings over entire speed, temperature and pressure range.
- Exclusive, non-galling Waukesha "88" alloy rotors are standard; permits running at tighter clearances and pumping a wide range of viscosities.

Equipment Serial Number

All Waukesha Cherry-Burrell pumps are identified by a serial number on the gear case nameplate, which is stamped on the pump body and cover.



CAUTION: The gear case, body, and cover must be kept together as a unit due to backface, rotor, and cover clearances. Failure to do so will damage the pump.

Pump Shaft Location

There are two pump drive shaft locations:

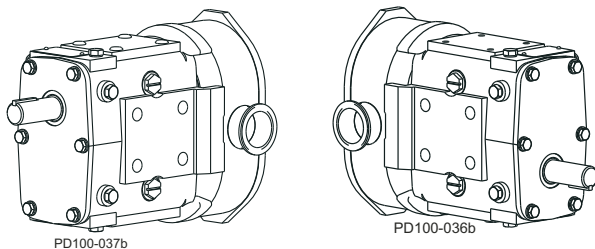

Figure 1 - Upper and Lower Shaft Mount

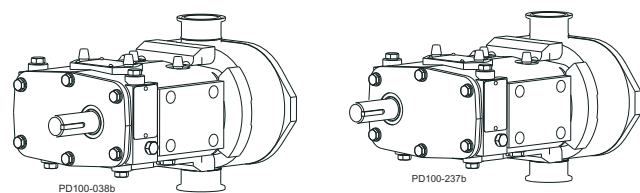

Figure 2 - Sidemount Left Hand and Right Hand
(as viewed from pump cover)

Operating Parameters

UI Model	Displacement per revolution	Maximum Nominal Capacity	Inlet/Outlet	Optional Inlet/Outlet	Maximum Pressure Range	Maximum RPM	Temp Range*
006	.0082 gal. (.031 liter)	6 gpm (1.3 m ³ /hr.)	1"	1-1/2"	200 psi (13.8 bar)	800	Std. Rotors: -40°F (-40°C) to 200°F (93°C); Hot Clearance Rotors: -40°F (-40°C) to 300°F (149°C)
015	.0142 gal. (.054 liter)	9 gpm (2.0 m ³ /hr.)	1-1/2"	-	200 psi (13.8 bar)	700	
018	.029 gal. (.110 liter)	17 gpm (3.8 m ³ /hr.)	1-1/2"	2"	200 psi (13.8 bar)	600	
030	.060 gal. (.227 liter)	36 gpm (8.2 m ³ /hr.)	1-1/2"	2"	200 psi (13.8 bar)	600	
040	.076 gal. (.288 liter)	45 gpm (10.2 m ³ /hr.)	2"	2-1/2"	150 psi (10.3 bar)	600	
060	.153 gal. (.579 liter)	90 gpm (20.4 m ³ /hr.)	2-1/2"	3"	200 psi (13.8 bar)	600	
130	.254 gal. (.961 liter)	150 gpm (34.1 m ³ /hr.)	3"	-	200 psi (13.8 bar)	600	
220	.522 gal. (1.976 liter)	310 gpm (70.4 m ³ /hr.)	4"	-	200 psi (13.8 bar)	600	
320	.754 gal. (2.854 liter)	450 gpm (102 m ³ /hr.)	6"	-	200 psi (13.8 bar)	600	

Rectangular Flange Models

UI Model	Displacement per revolution	Maximum Nominal Capacity	Inlet W x L Inches	Outlet	Maximum Pressure Range	Max. RPM	Temp Range *
014	.0142 gal. (.054 liter)	5.68 gpm (1.3 m ³ /hr.)	1.44 x 4.94	1-1/2"	200 psi (13.8 bar)	400	Std. Rotors: -40°F (-40°C) to 200°F (93°C); Hot Clearance Rotors: -40°F (-40°C) to 300°F (149°C)
024	.026 gal. (.110 liter)	11 gpm (2.5 m ³ /hr.)	1.31 x 4.93	1-1/2" (2")	200 psi (13.8 bar)	400	
034	.060 gal. (.227 liter)	24 gpm (5.5 m ³ /hr.)	1.75 x 6.75	2"	200 psi (13.8 bar)	400	
064	.153 gal. (.579 liter)	60 gpm (13.6 m ³ /hr.)	2.24 x 8.82	2-1/2" (3")	200 psi (13.8 bar)	400	
134	.254 gal. (.961 liter)	100 gpm (22.7 m ³ /hr.)	2.97 x 9.25	3"	150 psi (10.3 bar)	400	
224	.522 gal. (1.976 liter)	200 gpm (45.4 m ³ /hr.)	3.87 x 11	4"	200 psi (13.8 bar)	400	
324	.754 gal. (2.854 liter)	300 gpm (68.1 m ³ /hr.)	5 x 17.38	6"	200 psi (13.8 bar)	400	

Aseptic Models

UI Model	Displacement per revolution	Maximum Nominal Capacity	Inlet/Outlet	Maximum Pressure Range	Maximum RPM	Temp Range *
033A	.051 gal. (.193 liter)	30 gpm (6.8 m ³ /hr.)	1-1/2"	225psi (15.5 bar)	600	Std. Rotors: -40°F (-40°C) to 200°F (93°C); Hot Clearance Rotors: -40°F (-40°C) to 300°F (149°C)
133A	.205 gal. (.776 liter)	120 gpm (27.3 m ³ /hr.)	3"	225psi (15.5 bar)	600	
223A	.440 gal. (1.666 liter)	260 gpm (59.1 m ³ /hr.)	4"	225psi (15.5 bar)	600	
323A	.616 gal. (2.332 liter)	360 gpm (81.8 m ³ /hr.)	6"	225psi (15.5 bar)	600	

* Contact WCB Application Engineering for higher pressures or higher temperature applications.

"Standard" clearance rotors may be used with liquid temperatures up to 200°F (93°C). However, between 180°-200°F (82°-93°C), consider other application factors such as:

- speed of operation
- differential pressure
- lubricating properties of liquid being pumped.

If these factors trend toward a difficult application (high speed, high pressure, non-lubricating) then "Front Face" or "Hot" clearance rotors are recommended.

Factory Remanufacturing Program

Waukesha Cherry-Burrell Universal I pumps are designed so that they may be factory remanufactured twice and backed with a new pump warranty each time.

Factory remanufacturing involves replacement of all shafts, bearings, oil seals, gears, etc. The pump body and cover are re-machined and new oversized rotors are installed. The pumps are stamped R-1 or R-2, after the serial number, designating that they have been reconditioned once or twice.

Contact your Waukesha Cherry-Burrell Customer Service Representative at 1-800-252-5200 and furnish the serial number of any pump being considered for remanufacturing.

Installation

Install the pump and piping system in accordance with local codes and restrictions. Practices described in this manual are recommended for optimum performance.

All system equipment, such as motors, sheaves, drive couplings, speed reducers, etc., must be properly sized to ensure satisfactory operation of your Waukesha Cherry-Burrell pump within its limits.



CAUTION: *These pumps are positive displacement, low slip design and will be severely damaged if operated with closed valves in discharge or inlet lines. The pump warranty is not valid for damages caused by a hydraulic overload from operation or start-up with a closed valve in the system.*

Install Pump and Drive Unit



WARNING: *Full guards must be installed to isolate operators and maintenance personnel from rotating components. Guards are provided with Waukesha Cherry-Burrell pumps as part of a complete pump and drive package.*

In a typical installation configuration, the pump and drive unit are mounted on a common base plate. The unit can be installed in any of the arrangements shown in Figure 3 through Figure 6 (the shaded area indicates the guard location).

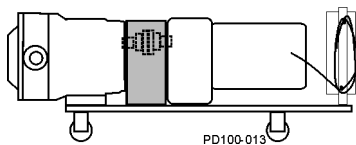

Figure 3 - Portable Base

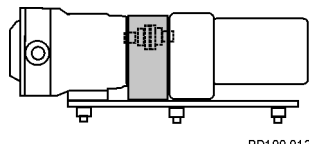

Figure 4 - Adjustable Leg Base

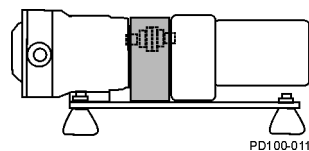

Figure 5 - Leveling and/or Vibration Isolation Pads

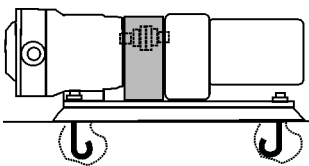

Figure 6 - Permanent Installation on Foundation

NOTE: *When installing unit as shown in Figure 6, level the unit before installing the bolts.*

Install Connections and Piping

Fittings

Waukesha Cherry-Burrell produces a wide variety of fittings made to fit your needs. Contact Waukesha Cherry-Burrell Customer Service at 1-800-252-5200 or 262-728-1900 for information on fittings.

Piping Support

To minimize forces exerted on the pump, support all piping to the pump independently with hangers or pedestals. Such forces can cause misalignment of the pump parts and lead to excessive wear of rotors, bearings, and shafts.

Figure 7 shows typical supporting methods used to independently support each pipe, reducing the weight effect of piping and fluid on the pump.

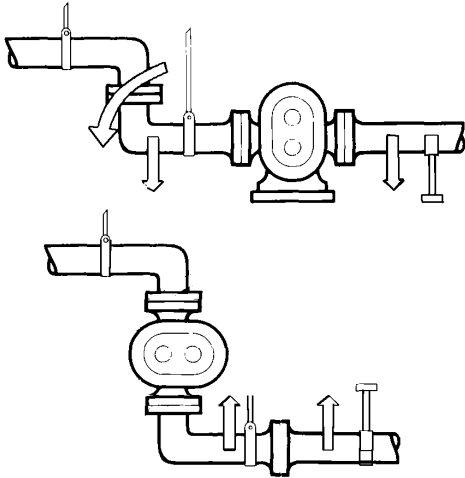

Figure 7 - Piping Support

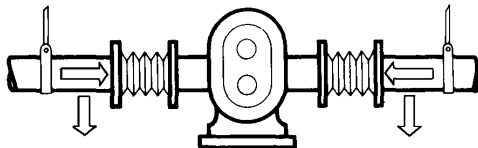

Figure 8 - Flexible Connections and Supports

Expansion Joints

Thermal expansion of piping can cause tremendous forces. Use thermal expansion joints to minimize these forces on the pump.

Flexible joints can be used to limit transmission of mechanical vibration. Ensure that the free ends of any flexible connections in the system are anchored.

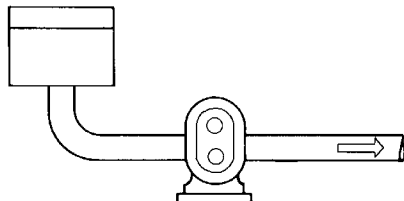
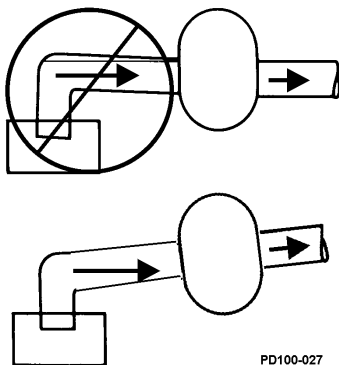

Figure 9 - Pump Below Supply

Inlet Piping

Install the pump below the supply liquid level to reduce the air in the system by flooded suction (Figure 9).



PD100-027

Figure 10 - Correct Piping to Prevent Inlet Air Pockets

If the pump is installed above the supply liquid level, the piping on the inlet side must slope up toward the pump, preventing air pockets in the pipes (Figure 10).

Install Check Valves

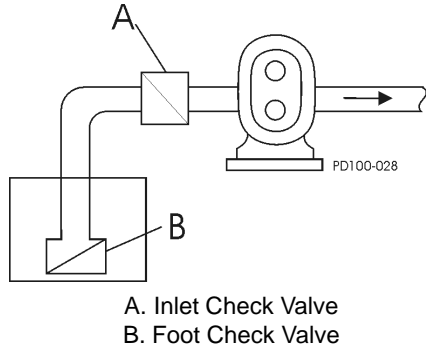

A. Inlet Check Valve
B. Foot Check Valve

Figure 11 - Inlet Check Valve

Inlet Side on Lift Applications

Use check valves to keep the inlet line full, particularly with low-viscosity fluids (Figure 11).

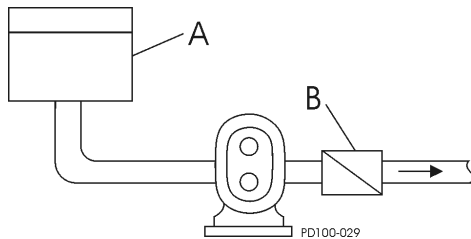

A. Closed Tank - produces vacuum on liquid (Low Absolute Pressure)
B. Check Valve (outlet)

Figure 12 - Discharge Check Valve

Discharge Side

For systems with liquid under a vacuum, install a check valve on the discharge side of the pump. The check valve prevents backflow (air or fluid) to aid in the initial start-up by minimizing the required differential pressure supplied by the pump to start the flow (Figure 12).

Install Isolation Valves

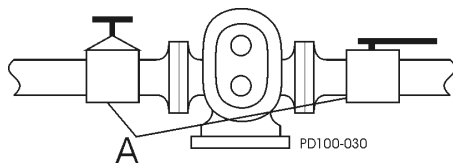

Figure 13 - Isolation Valves

Isolation valves permit pump maintenance and safe pump removal without draining the system (Figure 13, item A).

Install Relief Valves

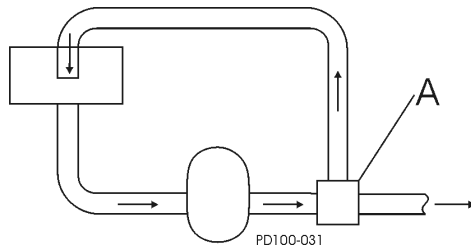
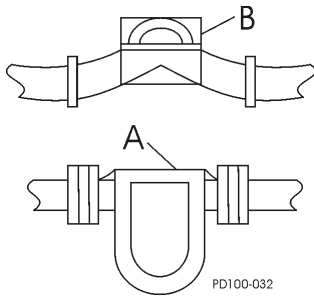

Figure 14 - Relief Valves

Install relief valves to protect the pump and piping system against excessive pressure. We recommend installing an external relief valve designed to bypass fluid from the pump outlet to the inlet side of the system (Figure 14, item A).

NOTE: Integral relief valves are available, but are not recommended on applications with viscosities over 5000 cP or where the discharge must be closed for more than a few minutes. Prolonged operation of the pump with closed discharge will cause heating of fluid circulating through the relief valve. If this is the case, install an external relief valve to discharge externally through the piping connected to the fluid source, or into inlet piping near the source.

Inlet Side Strainers and Traps



A. Strainer B. Magnetic Trap

Figure 15 - In-line Strainers and Traps

Inlet side strainers and traps (Figure 15, items A and B, respectively) can be used to prevent foreign matter from damaging the pump. Select carefully to prevent cavitation caused by the restriction of the inlet. If inlet strainers are used, they must be serviced regularly to prevent clogging and flow stoppage.

Install Pressure Gauges

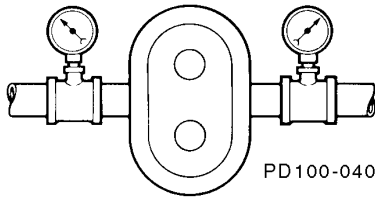

Figure 16 - Pressure and Vacuum Gauges

Pressure and vacuum gauges provide valuable information about pump operation (Figure 16). Wherever possible, install the gauges to help provide information on the following:

- Normal or abnormal pressures
- Indication of flow
- Changes in pump condition
- Changes in system conditions
- Changes in fluid viscosity

Check Coupling Alignment



Figure 17 - Lovejoy Coupling

Pumps and drives ordered from the factory and mounted on a common base plate are aligned before shipment. Alignment **must** be re-checked after the complete unit has been installed and piping completed. Periodic re-checking is advisable during the pump service life.



Figure 18 - T.B. Woods® Coupling

WCB recommends using a flexible coupling to connect the drive to the pump. Several different types are available, including couplings with slip or overload provisions. Waukesha Cherry-Burrell provides Lovejoy (Figure 17) or T.B. Woods® (Figure 18) couplings unless otherwise specified when ordering. Flexible couplings can be used to compensate for end play and small differences in alignment.

Align the pump and drive shaft as closely as possible:

- Pump and Drive are factory aligned.
- Re-check alignment after installation and before start-up.
- Re-check alignment periodically, to maximize service life.

Check Angular Alignment

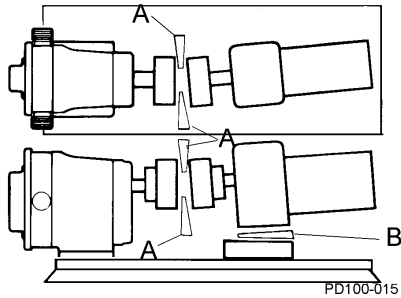

Figure 19 - Check Angular Alignment

1. Using feeler gauges or taper gauges (Figure 19, items A and B), check the alignment at four points every 90 degrees around the coupling; **adjust to equal dimension at all points.**
2. Set the space between the coupling halves to the manufacturer's recommended distance.
3. Install shims to bring the system into alignment.

Check Parallel Alignment

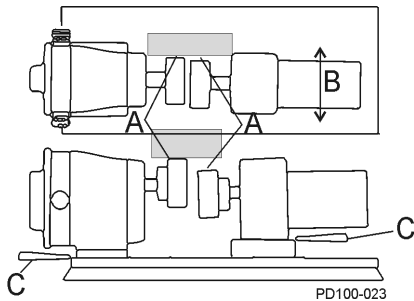

Figure 20 - Check Parallel Alignment

1. Check both the horizontal and vertical alignment of the pump and drive using a straight edge.
2. Using a feeler gauge at location "A" in Figure 20, determine the direction and amount of movement needed (Figure 20, item B).
3. If necessary, shim at location "C" and/or move drive as needed.

Check Belt and Chain Drive Alignment

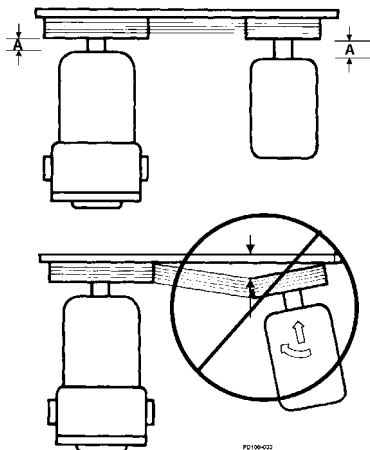

Figure 21 - Aligning Belt and Chain Drives

Use a straight edge to visually check the belt or chain alignment. Keep the shaft distance to a minimum (Figure 21, item A).

After the piping is complete and before the belts are installed, manually turn the pump shaft to ensure it turns freely.

Check Pump Rotation

Check the direction of the drive rotation to determine the rotation direction of pump (Figure 22). After the correct drive rotation is verified, connect the coupling and assemble the pump and coupling guards.

NOTE: The pump covers in the following figures have been removed to view the rotor rotation. Never operate the pump with the covers removed.

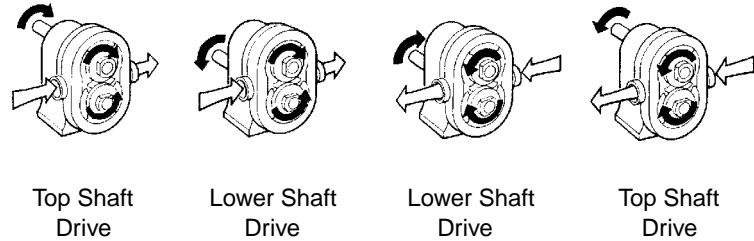

Figure 22 - Direction of Drive Rotation

Operation



DANGER: The pump contains internal moving parts. DO NOT put hands or fingers into the pump body ports or drive area at any time during operation. To avoid serious injury, DO NOT install, clean, service, or repair the pump unless all power is off and locked out.



CAUTION: These pumps are positive displacement, low slip design and will be severely damaged if operated with closed valves in the discharge or inlet lines. The pump warranty is not valid for damages caused by a hydraulic overload from operation or start-up with a closed valve in the system.

Pre-Startup Checklist



CAUTION: Do not use this pump to flush a newly- installed system. Severe damage may occur to the pump and system if the pump is used to flush the system.

Remove the rotors during system flushing.



WARNING: Full guards must be installed to isolate the operators and maintenance personnel from the rotating components. Guards are provided with Waukesha Cherry-Burrell pumps as part of a complete pump and drive package.



WARNING: Do not start a pump with seal flush unless the seal flush is installed and on.

1. Ensure that the pump is correctly installed as described in “Installation” on page 13. Review “Install Relief Valves” on page 15 and install relief valves as needed.
2. Check the coupling alignment. See “Check Coupling Alignment” on page 16.
3. Ensure that the pump and piping are clean and free of foreign material such as welding slag, gaskets, etc.
4. Ensure that all piping connections are tight and leak-free. Where possible, check the system with non-hazardous fluid.
5. Ensure that the pump and drive are lubricated. See “Lubrication” on page 20.
6. Ensure that all guards are in place and secure.
7. Double mechanical seals require adequate supply and flow of clean flushing fluids.
8. Ensure that all valves are open on the discharge side and a free flow path is open to the destination.
9. Ensure that all valves are open on the inlet side and fluid can fill the pump. A flooded suction installation is recommended.
10. Check the direction of pump and drive rotation to ensure that the pump will rotate in the proper direction. See “Check Pump Rotation” on page 18.

Startup Procedure

1. Start the pump drive. Where possible, start at a slow speed or jog.
2. Ensure that the liquid is reaching the pump within 60 seconds. If pumping does not begin and stabilize, check “Troubleshooting” on page 98.

Shutdown Procedure

1. Shut off the power to the pump drive.
2. Shut off the supply and discharge lines.

Emergency Shutdown Procedure

Emergency Shutdown Procedures should be documented by plant personnel after assessing system-wide requirements.

Maintenance

Important Safety Information



DANGER: The pump contains internal moving parts. DO NOT put hands or fingers into the pump body ports or drive area at any time during operation. To avoid serious injury, DO NOT install, clean, service, or repair the pump unless all power is off and locked out.

Before detaching port connections to the pump:

- Close the suction and discharge valves.
- Drain the pump and clean or rinse, if necessary.
- Disconnect or shut off the electrical supply and lock out all power.

Lubrication

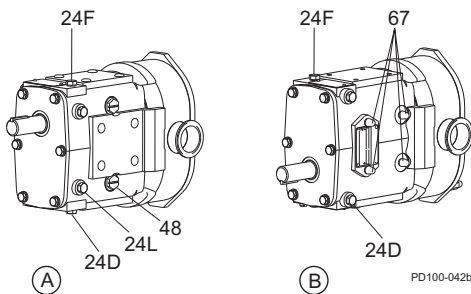

Figure 23 - Lubrication Points

A. Upper Shaft Drive Pump (Standard)
B. Lower Shaft Drive Pump (Optional)
24D. Oil Drain Plug
24F. Oil Fill Plug
24L. Oil Level Check Plug, Sightglass
48. Grease Clean-out Plug
67. Grease Fittings

Drive Lubrication

Refer to the manufacturer's manual shipped with the drive for proper drive lubrication and frequency.

Gears

Gears are factory-lubricated with gear oil at the quantity shown in Table 1. **Change the oil every 750 hours.** Aggressive washdown or extreme running conditions may require more frequent lubrication intervals.

Gear Oil Specification

ISO Grade 320, SAE 140 or AGMA Number 6EP.

Bearings

Bearings are factory-lubricated with grease. Re-lubricate them at the quantity shown in Table 1. **Grease the bearings every 750 hours.** Aggressive washdown or extreme running conditions may require more frequent lubrication intervals.

Excess grease will accumulate in the gear case and must be removed through the cleanout hole covered with a plastic plug (Figure 23, item 48).

Bearing Lubricant Grease

NLGI Grade No. 2, EP, Lithium-based lubricant is standard.

Table 1: Lubrication Quantities

Universal I Model	Oil Capacity (Gears)		Grease Quantity (per Bearing)	
	Top or Bottom	Side Mount	Front	Rear
006, 014, 015, 018, 024	1.3 oz (40 ml)	3.3 oz (100 ml)	0.37 oz (11 cc)	0.13 oz (4 cc)
030, 033A, 034, 040	2.0 oz (60 ml)	4 oz (120 ml)	0.60 oz (18 cc)	0.21 oz (6 cc)
060, 064, 130, 133A, 134	6.0 oz (170 ml)	9.5 oz (280 ml)	0.84 oz (25 cc)	0.76 oz (22 cc)
220, 223A, 224	11 oz (320 ml)	20 oz (600 ml)	1.33 oz (39 cc)	1.03 oz (30 cc)
320, 323A, 324	17 oz (500 ml)	44 oz (1300 ml)	1.96 oz (58 cc)	1.16 oz (34 cc)

Maintenance Inspections



DANGER: The pump contains internal moving parts. DO NOT put hands or fingers into the pump body ports or drive area at any time during operation. To avoid serious injury, DO NOT install, clean, service, or repair the pump unless all power is off and locked out.

Detecting wear in the early stages can reduce repair costs and down time. A simple “look-feel” inspection of the pump during breakdown cleaning is recommended to detect signs of trouble at an early stage.

A detailed maintenance inspection should be scheduled annually. See “Annual Maintenance” on page 24.

Refer to the “Maintenance Inspection Chart” on page 23 for possible causes and solutions to common issues discovered during inspection.

Inspection of Rotor Tips

Remove the cover (see “Remove Cover” on page 25) and check for metal-to-metal contact between the rotor wings. When contact is detected, repair or replace the pump.

Visually inspect the rotors for rotor tip to rotor tip contact and rotor tip to rotor hub contact. Manually rotate the pump drive shaft and ensure that the rotor tip clearance is equal on both sides as indicated in Figure 24.

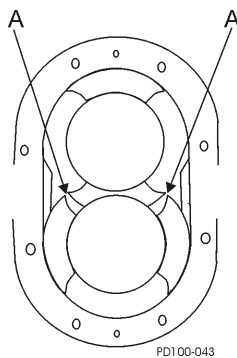

Figure 24 - Rotor to Rotor Tip Clearance

Inspection of Shaft and Shaft Shoulder

Visually inspect the shaft for twists or bends; replace it as necessary. Visually inspect the shaft shoulder (Figure 25) for excessive wear; replace it as necessary. If the shaft shoulder has a sharp edge, remove the edge with a file to prevent cutting the shaft o-ring on installation.

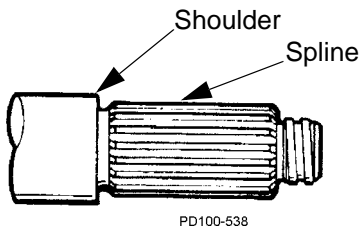

Figure 25 - Shaft Inspection

Inspection of Rotor Hub End

Visually inspect the rotor hub end (Figure 26) for excessive wear; replace it as necessary. Each time the rotors are removed, replace the o-rings on the hub.

NOTE: Rotor hub and shaft shoulder wear are caused by operating with a loose rotor nut(s) for extended periods.

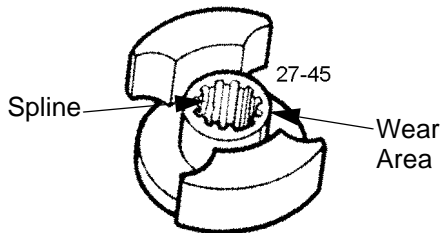

Figure 26 - Rotor Inspection

Inspection of Gears and Bearings

Gear backlash

With the fluid head and seals removed, feel for gear backlash by rotating either shaft by hand. The other shaft must engage immediately. Perform this check three times at 60-degree intervals. If play (backlash) is evident, remove the gear case cover, check the gear teeth for wear, and ensure that the gear is not loose on the shaft. If the gear teeth are worn, replace the gears. If the gear is loose on the shaft, inspect the shaft key and keyway; replace as necessary.

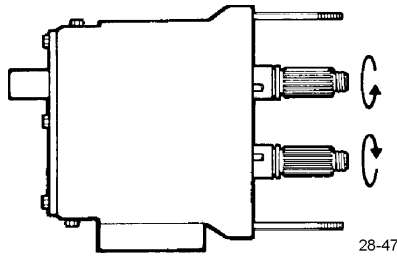

Figure 27 - Backlash Check

Check bearing condition

With the fluid head and seals removed, check the bearing condition by applying (by hand) an up or down force of approximately 30 lbs (14 kg). If movement is detected, the bearing may be failing. Also check the shaft movement forward or backward. If the bearing is failing, replace the bearing and review the lubrication section 20.

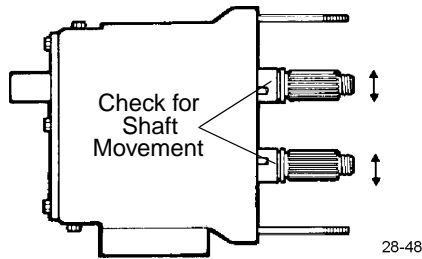

Figure 28 - Bearing Deflection Check

Maintenance Inspection Chart

Problem	Possible Causes	Possible Solutions
Rotor tip to rotor tip contact or uneven rotor tip to rotor tip clearance.	Hard object jammed into rotors and twisted shafts.	Replace shafts. Install strainers if necessary. Check and replace gears if necessary.
Rotor tip to rotor hub contact.	Loose rotor nut(s). Belleville-style washer(s) on backwards. Backface clearances not even. Bearings need replacing.	Torque rotor nut(s) properly. Install belleville-style washers correctly. Verify backface clearances are even. Check and replace bearings.
Worn rotor or shaft splines.	Loose rotor nut(s). Belleville-style washer(s) on backwards.	Replace rotors, shafts. Torque rotor nut(s). See "Torque Values and Wrench Size" on page 48. Install belleville-style washer(s) correctly.
Worn rotor hub end or shaft shoulder.	Loose rotor nut(s). Belleville-style washer(s) on backwards. Rotors slammed against shoulder when installed.	Torque rotor nut(s). See "Torque Values and Wrench Size" on page 48. Install belleville-style washer(s) correctly. Replace rotors and shafts or shim front bearing(s) to maintain proper backface clearances.
Sharp edged shaft shoulder.	Loose rotor nut(s). Belleville-style washer(s) on backwards. Rotors slammed against shoulder when installed. Backface clearances not even.	Remove sharp edge with file to prevent cutting shaft o-ring. Verify backface clearances are even.
Gear backlash.	Lack of lubrication. Excessive hydraulic loads. Loose gear locknuts.	Check lubrication level and frequency. Reduce hydraulic loads. Torque locknuts to specified torque values. See "Torque Values and Wrench Size" on page 48. Check and replace gears if necessary.
Worn or broken gear teeth.	Lack of lubrication. Excessive hydraulic loads. Loose gear locknuts.	Check lubrication level and frequency. Reduce hydraulic loads. Torque locknuts to specified torque values. See "Torque Values and Wrench Size" on page 48. Check and replace gears if necessary.
Loose gears.	Gear locknuts not torqued properly. Locking assembly not torqued properly. Worn gear key.	Torque gear nut to specified torque value. See "Torque Values and Wrench Size" on page 48. Check and replace gears if necessary. Inspect gear key, shaft keyway and shaft, replace if necessary.
Loose bearings, axially or radially.	Lack of lubrication. Excessive hydraulic loads. Product or water contamination.	Check lubrication level and frequency. Reduce hydraulic loads. Ensure no excess grease build-up. Replace bearings if necessary.
Damaged front grease seals.	Seal may be old and worn. No grease on lips to lubricate. Shaft worn under seals.	Replace seals. Properly lubricate with grease when installing. Inspect shaft surface under seals.
Damaged rear oil seals.	Seal may be old and worn. No grease on lips to lubricate. Shaft worn under seals. Not centered on shaft when installed.	Replace seals. Properly lubricate with grease when installing. Inspect shaft surface under seals.

Annual Maintenance



DANGER: The pump contains internal moving parts. DO NOT put hands or fingers into the pump body ports or drive area at any time during operation. To avoid serious injury, DO NOT install, clean, service, or repair the pump unless all power is off and locked out.

At least annually, perform the procedures and corrective measures outlined in “Maintenance Inspections” on page 21, in addition to the following preventive maintenance:

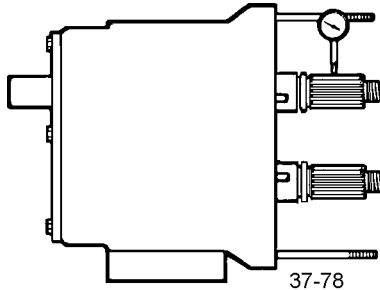

Figure 29 - Check bearings

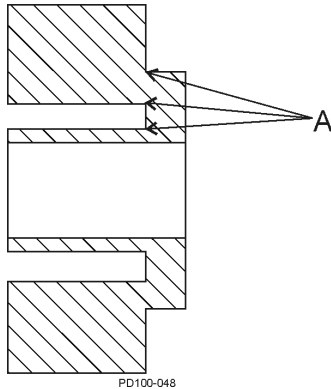

Figure 30 - Rotor Stress Points

- Check the bearings with a dial indicator for shaft radial play (Figure 29). If the deflection is equal to or greater than the rotor-to-body diametrical clearance (“Checking for Proper Clearance” on page 41), replace the bearings.
- Remove the gear cover and inspect the gears for wear, backlash and looseness. Loosen and torque the gear retaining nuts to the proper torque. See Table 8 on page 48.
- Thoroughly inspect the rotors for worn keyways, hub wear and stress cracks (Figure 30, item A). Use the dye check method to detect any fatigue-type cracks at rotor stress points.
- Review the performance record on the pump, and check the radial and backface clearances to determine wear and effect on performance. See **Table 4, “Standard Rotor Clearance,”** or Table 5, “Hot Rotor Clearance,” on page 42. Adjustment to the operating speed can compensate for wear in some applications.



CAUTION: When bearings or shafts are replaced in the field, take care to correctly position the shaft by shimming it to maintain sufficient running clearances between the rotor wing faces and the pump body faces (backface and cover face). It is important to hold the same backface dimension for both rotors to avoid crossover interference.

Cleaning

Use a basket or wash tank with a rubber mat covering the bottom. Wash the parts thoroughly with a cleaning compound using brushes and plenty of fresh warm water at about 125°F (52°C). Rinse the parts thoroughly with 170°F (77°C) water and store them to permit free draining and natural drying. Reassemble the pump and sterilize it in accordance with accepted sterilizing practices. If a chlorine solution (200 ppm available chlorine) is used, it should leave no residual deposits which would remain in the pump.

NOTE: Acid cleaners have a much higher metal corrosion rate and pump parts should remain in acid cleaning solutions no longer than necessary. Any strong inorganic mineral-based acids that are harmful to your hands would be harmful to pump parts. Due to the high circulation required, Waukesha Cherry-Burrell recommends that its pumps not be used to recirculate cleaning solutions.

Fluid Head Disassembly (All Models)



DANGER: The pump contains internal moving parts. DO NOT put hands or fingers into the pump body ports or drive area at any time during operation. To avoid serious injury, DO NOT install, clean, service, or repair pump unless all power is off and locked out.



DANGER: To avoid serious injury, shut off and drain product from the pump prior to disconnecting the piping.

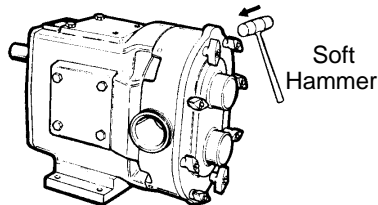

Soft Hammer

Figure 31 - Remove Cover Nuts

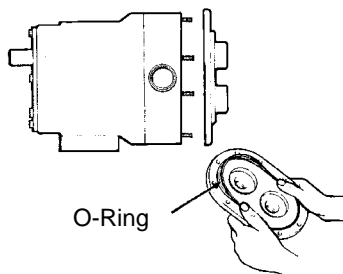

O-Ring

Figure 32 - Remove O-Ring

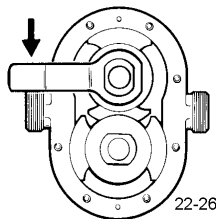

22-26

Figure 33 - Remove Rotor Retaining Nuts

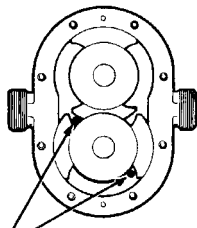

Apply gear puller here

Figure 34 - Apply Gear Puller

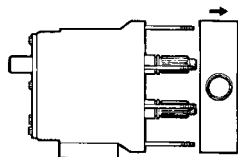

Figure 35 - Remove Pump Body

Remove Cover

1. Remove the cover wing nuts from the cover using a soft hammer to loosen them (Figure 31).

2. Remove the cover. If it is stuck, loosen it with a soft hammer. Remove and discard the cover o-ring (Figure 32).

3. Place the cover on a protected surface with the finished surfaces facing up.

4. Remove the rotor retaining nuts. Use the special wrench supplied with the pump and hit the handle sharply with a soft hammer to loosen the nuts (Figure 33).

5. Orient the rotors perpendicular to each other and remove the rotor with both wings exposed first. Handle the rotors with care to avoid nicks and scratches. If the rotor is stuck tight, use a gear puller or hardwood lever behind the rotor hub to force it off the spline (Figure 34).

6. Remove the pump body by pulling it straight off the studs (Figure 35). Use a soft hammer to assist if the body is stuck tight.

7. See "Seal Maintenance" on page 27 for the seal disassembly procedure.

8. Clean and inspect the body thoroughly.



CAUTION: The body must be reassembled on the bearing housing from which it was removed. Both are identified with the same serial number.

Model 320 and 324 Body Disassembly

After removing the cover and rotors, remove the four bolts from each seal gland and slide the gland toward the gear case. Loosen the two socket head cap screws from the front of the body. Tap the body with a soft hammer to drive the body loose from the gear case and dowel pins.

Model 323 Aseptic Body Disassembly

1. Disconnect the flushing lines.
2. Remove the cap screws from the seal flush glands and slide the glands back against the gear case.

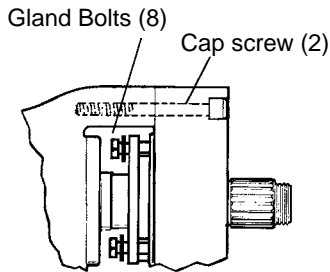

Figure 36 - Remove Capscrews

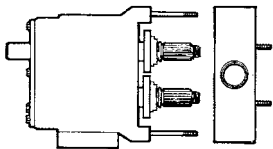

Figure 37 - Remove Pump Body

3. Loosen the two socket head cap screws in the front of the body. Tap the body with a soft hammer to drive the body loose from the gear case and dowel pins.

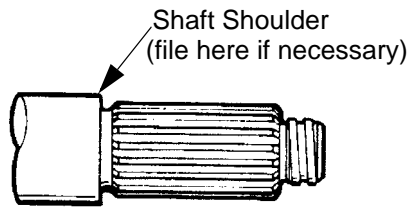

Figure 38 - Clean Shafts

4. Thoroughly clean the shafts. If the shaft shoulder has a sharp edge, remove the edge with a file to prevent cutting the shaft o-ring when disassembling the seal seat.

Seal Maintenance

NOTE: To service seals, it is necessary to disassemble the fluid head. See "Fluid Head Disassembly (All Models)" on page 25.

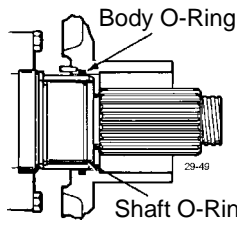

Figure 39 - Remove O-Rings

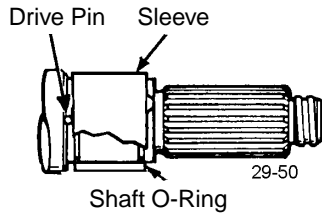

Figure 40 - Remove Shaft Sleeve

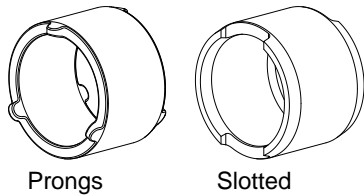

Figure 41 - Shaft Sleeves

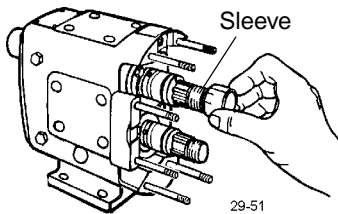

Figure 42 - Assemble Shaft Sleeves

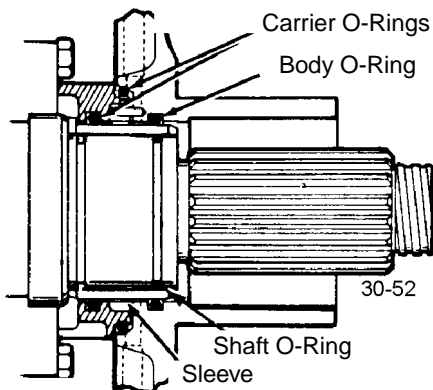

Figure 43 - Double O-Ring

O-Ring

Service

1. Remove and discard the body o-rings, using the o-ring removal tool furnished with the pump.
2. Remove shaft sleeves and shaft o-rings.
3. Thoroughly clean and inspect grooves, shafts and sleeves. DO NOT re-use sleeves that are grooved or scratched.

Assembly

1. Apply an approved o-ring lubricant to the NEW o-rings and insert them into the body grooves and shaft grooves. The shaft o-rings should be installed into the front shaft groove (closest to the shaft spline) when using o-ring seals. Sleeves may be either slotted or have prongs.
2. Assemble the shaft sleeves against the shaft shoulder, making sure that the sleeve prongs DO NOT line up with the drive pin on the shaft. However, do place the slotted sleeve over the pin if you have that type of sleeve.
3. See page 44 for fluid head assembly procedure.

Double O-Ring

Service

1. Remove the o-ring carriers.
2. Remove and discard the o-rings from both the body and carriers, using the o-ring removal tool furnished with pump.
3. Remove the shaft sleeves and shaft o-rings.
4. Thoroughly clean and inspect the body, carrier and shaft grooves, and sleeves.

NOTE: DO NOT re-use sleeves that are grooved or scratched.

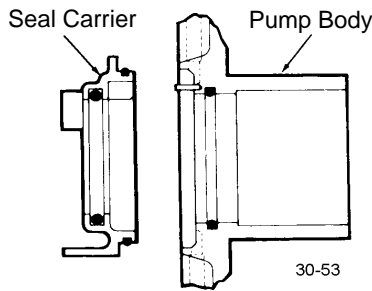

Figure 44 - Assemble Carriers into Body

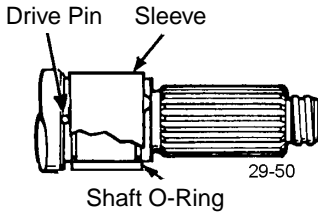

Figure 45 - Remove Shaft Sleeve

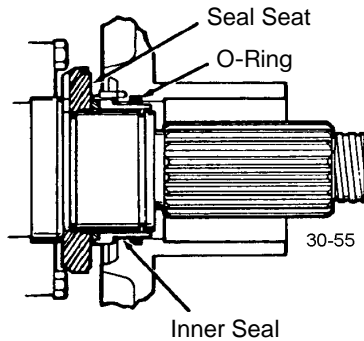

Figure 46 - Mechanical Seal

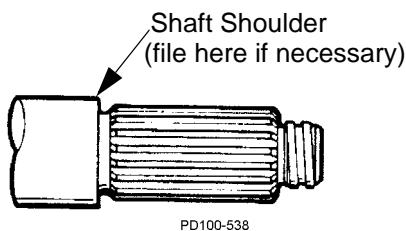

Figure 47 - Shaft Shoulder

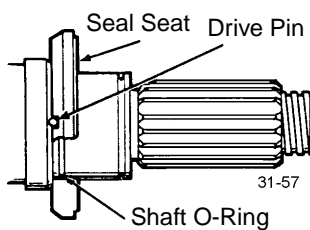

Figure 48 - Install O-Rings

Assembly

1. Apply an approved o-ring lubricant to the NEW o-rings and insert them into body, carriers and shaft grooves. Install the shaft o-rings into the front shaft groove (closest to the shaft spline) when using o-ring seals.
2. Assemble the carriers into the body so that the notch in the carrier engages the pin in the body.
3. Assemble the shaft sleeves against the shaft shoulder, making sure that the sleeve prongs DO NOT line up with the drive pin on the shaft.
4. See page 44 for fluid head assembly procedure.

Mechanical Seal

Service - Single Inside

1. Remove the seal from the body, then clean and inspect it thoroughly. DO NOT re-use if the seal face is scratched, chipped or cracked.
2. Remove the o-rings from the body and discard them. Use the o-ring removal tool supplied with pump.
3. If the shaft shoulder has a sharp edge, remove the edge with a file to prevent cutting the shaft o-ring when disassembling the seal seat. See Figure 47.
4. Remove the seal seats and shaft o-rings. Clean and inspect them thoroughly. DO NOT re-use seats that are cracked, chipped, scratched or grooved.

Assembly - Single Inside

1. Install NEW o-rings on the shafts. Lubricate the o-rings to aid in assembly of the seal seat.
2. Install the seal seats, making sure to line up the groove on the rear face with the drive pin on the shaft. Lubricate the face of the seat.
3. Lubricate and insert the NEW o-rings in the body grooves.

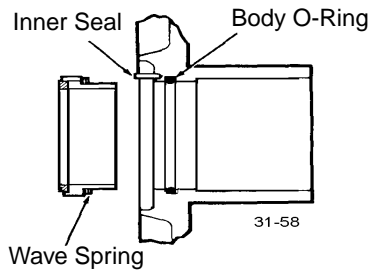

Figure 49 - Assemble Wave Spring

4. Assemble the wave spring on the seal and install it into the body with the notch engaging the pin in the body.
5. Lubricate the seal faces.
6. See page 44 for fluid head assembly procedure.

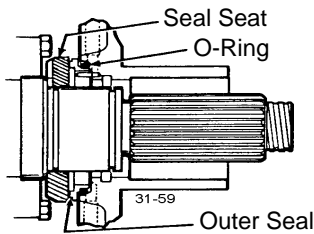

Figure 50 - Remove Seals

Service - Single Outer

1. Remove the seals from the body and discard the o-rings. Inspect the seal face thoroughly. DO NOT re-use seals that are cracked, chipped or scratched.

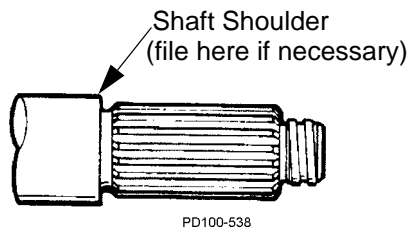

Figure 51 - Shaft Shoulder

2. If the shaft shoulder has a sharp edge, remove the edge with a file to prevent cutting the shaft o-ring when disassembling the seal seat.
3. Remove the seal seats and shaft o-rings. Clean and inspect them thoroughly. DO NOT re-use seats that are cracked, chipped, scratched, or grooved.

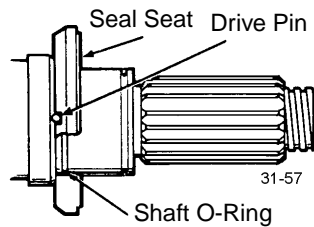

Figure 52 - Install O-Rings

Assembly - Single Outer

1. Install the NEW o-rings on the shafts and lubricate them to aid in assembly of the seal seat.
2. Install the seal seats, making sure to line up the groove on the rear face with the drive pin on the shaft. Lubricate the face of the seat.
3. Apply lubricant to the NEW o-rings for the seal and assemble them on the seals.
4. Insert the seal assembly into the body, engaging the notch with the pin. Push from the opposite side, over and in, to seat the o-ring.
5. Apply lubricant to the seal face.
6. See page 44 for fluid head assembly procedure.

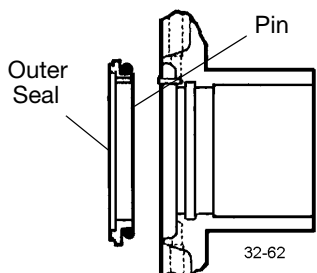

Figure 53 - Insert Seal Assembly

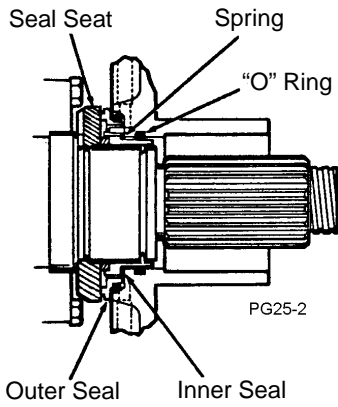

Figure 54 - Insert Seal Assembly

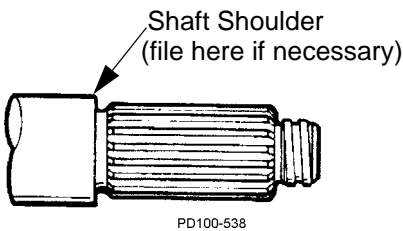

Figure 55 - Shaft Shoulder

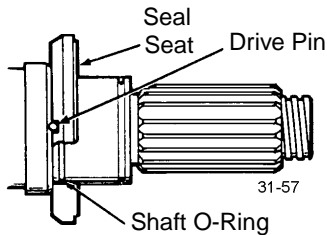

Figure 56 - Install O-Rings

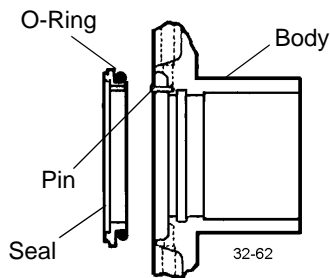

Figure 57 - Install Seal Seats

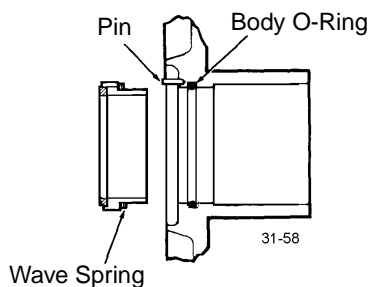

Figure 58 - Insert O-Rings

Double Concentric Seals and Aseptic Model Seals

Service - Outer Seal

Remove the seals from the body and discard the o-rings. Inspect the seal face thoroughly. DO NOT re-use seals that are cracked, chipped or scratched.

Service - Inner Seal

1. Remove seal from body, then clean and inspect thoroughly. DO NOT re-use if seal face is scratched, chipped or cracked.
2. Remove o-rings from body and discard. Use o-ring removal tool supplied with pump.
3. If the shaft shoulder has a sharp edge, remove the edge with a file to prevent cutting the shaft o-ring when disassembling the seal seat.
4. Remove seal seats and shaft o-rings. Clean and inspect thoroughly. DO NOT re-use seats that are cracked, chipped, scratched or grooved.

Assembly - Outer Seal

1. Install new o-rings on shafts and lubricate to aid in assembly of seal seat.

NOTE: On aseptic models, there are 2 o-rings per shaft.

2. Install seal seats, being sure to line up groove on rear face with drive pin on shaft. Lubricate face of seat.
3. Apply lubricant to NEW o-rings for seal and assemble on seals.
4. Insert seal assembly into body engaging notch with pin and pushing from opposite side, over and in, to seat o-ring.
5. Apply lubricant to seal face.

Assembly - Inside Seal

1. Lubricate and insert NEW o-rings in body grooves.
2. Assemble wave spring on seal and install into body with notch engaging pin in body.
3. Lubricate seal faces.
4. See Section 5 for fluid head assembly procedure, seals with a cracked, chipped or scratched seal face.

NOTE: Handle all seal components with extreme care to avoid damage.

Mechanical Seals - Model 320

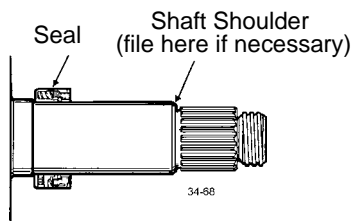

Figure 59 - Shaft Shoulder

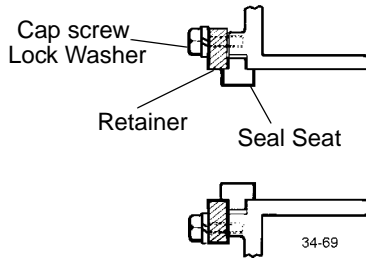

Figure 60 - Remove Seal Seat Retainer

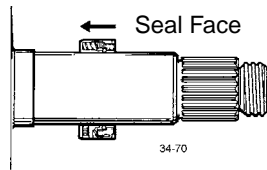

Figure 61 - Seal Rotating Assembly

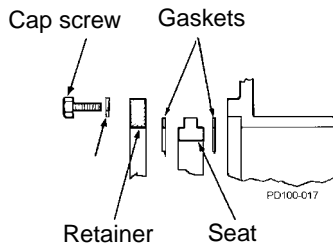

Figure 62 - Install Seal Components

Shaft / Seal Service

1. Remove seal from shaft by loosening the set screws and sliding it off.
2. If the shaft shoulder has a sharp edge, remove the edge with a file to prevent cutting the shaft o-ring when disassembling the seal seat.
3. Clean and inspect seal thoroughly. DO NOT re-use seals with a cracked, chipped or scratched seal face.
4. Remove seal seat retainer cap screws, lock washers and retainers from body.
5. Remove seal seat from body. Clean inspect thoroughly. DO NOT re-use a seal seat that is cracked, chipped, scratched or grooved.

NOTE: If one face of the seat is worn, the seat can be turned over to use the other face.

Assembly

1. Place seal rotating assembly onto shaft with seal face out. Position seal on shaft (see seal assembly drawing for correct dimension) and lock it with the set screws.
2. Install seal seat gasket, seal seat, retainer gasket, and seal seat retainer and secure them with wing nuts.
3. See page 44 for fluid head assembly procedure.

NOTE: Handle all seal components with extreme care.

Mechanical Seals - Model 323 Aseptic (323A)

Service

1. Remove inner seal by disengaging set screws in seal collar.
2. Slide inner seal, seal seat and gaskets off shaft.
3. Loosen outer seal set screws and pull seals off shafts. Remove burrs on shafts where set screws locked to aid in reassembly.
4. Clean and inspect all seal components thoroughly. **DO NOT** re-use a seal or seal seat that is cracked, scratched or grooved.

Assembly

1. Slip outer seals onto shafts and secure them in position with set screws. See seal drawing for mounting dimension.
2. Slide seal seat retainer, retainer gasket, seal seat, and seat gasket, in that order, onto shafts and place seal seat against the seat face of outer seal.

3. Install inner seal with seal face against seal seat and lock in position with set screws. See seal drawing for mounting dimension.

NOTE: Handle all seal components with extreme care

4. Mount pump body onto bearing housing and be sure seal seats are located in body counterbores. Secure body with 4 bolts.

5. Place seal seat retainer and retainer gaskets in position and secure with cap screws.

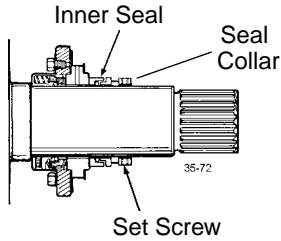

Figure 63 - Remove Inner Seal

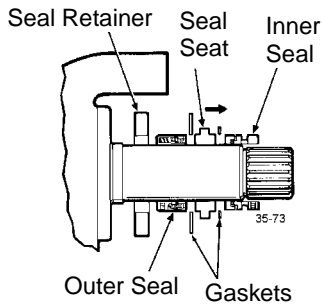

Figure 64 - Install Seal Components

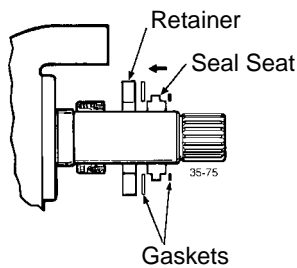

Figure 65 - Install Inner Seal

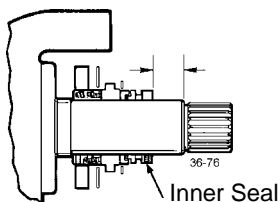

Figure 66 - Mount Pump Body

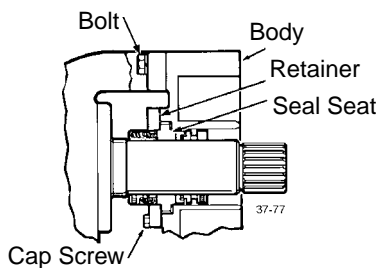

Figure 67 - Position Seal Seat Retainer

Gear Case Disassembly



DANGER: To avoid serious injury, DO NOT install, clean, service, or repair the pump unless all power is off and locked out.



DANGER: To avoid serious injury, shut off and drain product from the pump prior to disconnecting piping.

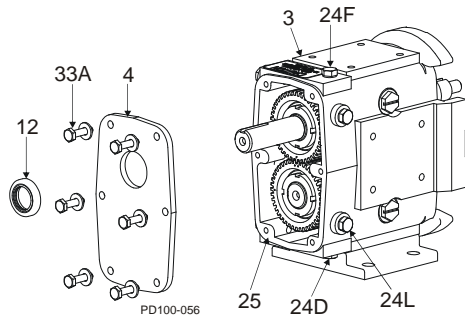

Figure 68 - Remove Gear Case Cover

3. Gear Case	24F. Oil Fill Plug
4. Gear Case Cover	24L. Oil Level Check Plug, Sight glass
12. Oil Seal	25. Silicone Sealant
24D. Oil Drain Plug	33A. Cap Screw

Remove Gear Case Cover

1. Remove the oil drain plug (Figure 68, item 24D); drain the oil.
2. Remove the cap screws from the gear case (Figure 68, item 33A).
3. Pull the cover (item 4) off the shaft extension. If the cover sticks, use a soft hammer to loosen it.
4. Remove the silicone sealant (item 25) from the gear case and cover.
5. Using an arbor press, remove the oil seal (item 12) from the cover. Discard the used oil seal.
6. Straighten the tab on the lock washers (Figure 69, item A).

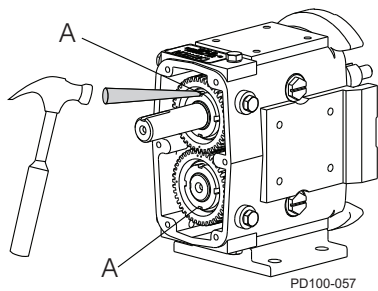

Figure 69 - Straighten Lock Tab on Lock Washers

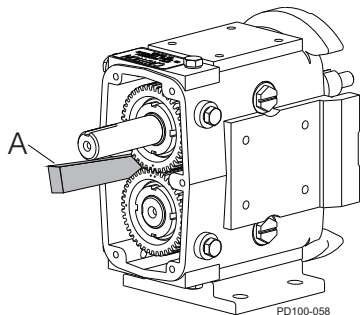

Figure 70 - Block Shaft Rotation

Remove Shaft

1. Prevent the shafts from turning by placing a wedge between the gears (Figure 70, item A).

NOTE: Protect the liquid end of the shafts by wrapping them with tape. See Figure 71 and Figure 73.

2. Use a spanner wrench or drift punch to remove the gear lock nut. The gears will be removed later.

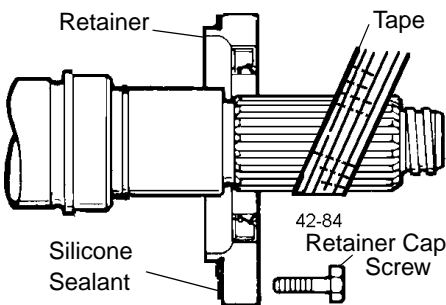

Figure 71 - Remove Bearing Retainers

3. Remove the front bearing retainer screws and pull off the bearing retainers (Figure 71). If a retainer is stuck, leave it in place; it will press out when the shaft is removed.

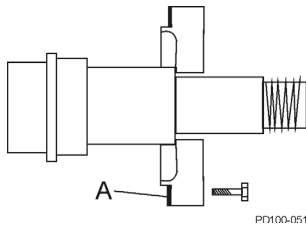

Figure 72 - Remove Sealant from Retainer

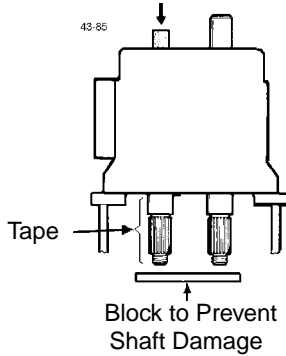

Figure 73 - Press Shafts from Gear Case

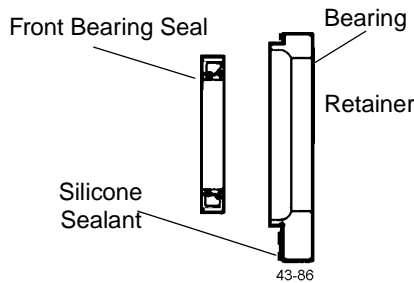

Figure 74 - Remove Rear Oil Seals

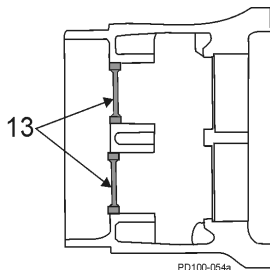

Figure 75 - Remove Rear Oil Seals

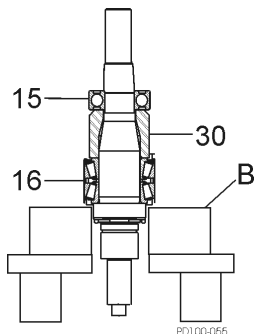

Figure 76 - Remove Bearings From Shaft

- Remove the silicone sealant (Figure 72, item A) from the bearing retainer and gear case.

NOTE: Protect the liquid end of the shafts by wrapping them with tape.

- Place the gear case on an arbor press with the liquid end facing down. Protect the shaft ends with a wood or plastic block (Figure 73) and press the shafts out of the gear case. See Table 9, "Arbor or Hydraulic Press Required (Tons)," on page 48.

- Press out and discard the front bearing seals from the front bearing retainers. Clean and reuse the bearing isolators, if installed.

- Remove the shims. If the shafts and bearings will be reused, identify the shims and bearings that belong with each shaft.

- Press out and discard both rear oil seals in the gear case (Figure 75, item 13).

- Use a hydraulic press and V-blocks (Figure 76, item B) to remove the bearings (items 15 and 16) and spacer (item 30)

NOTE: Make sure both ends of the shaft are protected when removing the shaft.

Shaft Assembly

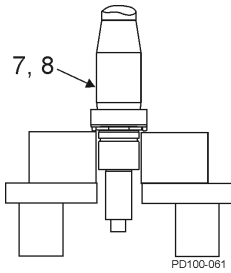

Figure 77 - Grease Shaft

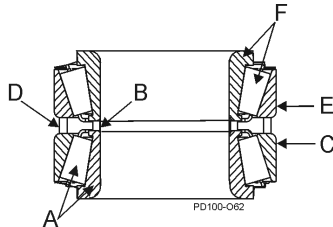

Figure 78 - Bearing assembly

Table 2: Callout table for Figure 78

A. Lower Cone / Roller Assembly	D. Outer Spacer
B. Inner Spacer	E. Upper Cup
C. Lower Cup	F. Upper Cone / Roller Assembly

Front Bearing Assembly

NOTE: The following instructions cover the assembly of a six-piece front bearing assembly. For a four-piece assembly, only one spacer and cup is used.

1. Lubricate the front bearing area of the shaft (Figure 77, item 7, 8) with oil or grease. Place it upright in a hydraulic press with the liquid end down.

2. Unwrap the front bearing assembly.

NOTE: DO NOT interchange the parts of one bearing assembly with another. The parts are precisely matched during manufacturing and must be installed as a matched assembly. See Figure 78.

1. Lift the lower cone and roller assembly (Figure 79, item A) out of the bearing stack and place it on the shaft with the radius facing down. Press it onto the shaft until it is seated against the shaft shoulder. **Press only on the inner cone.**

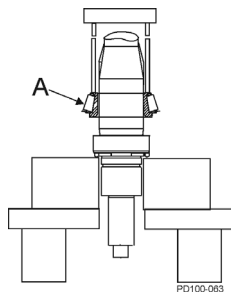

Figure 79 - Press Lower Cone onto Shaft

2. Place the inner spacer (Figure 80, item B) over the shaft onto the lower cone and roller assembly.
3. Place the lower cup (item C) over the lower cone and roller assembly, keeping the cup opening toward the assembly.
4. Place the outer spacer (item D) over the shaft and onto the lower cup.

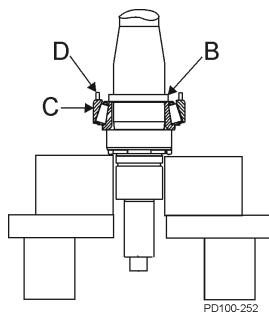

Figure 80 - Install Inner & Outer Spacer and Lower Cup

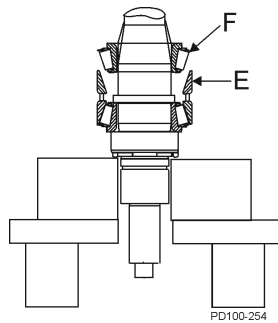

Figure 81 - Install Upper Cup & Upper Cone

5. Place the upper cup (Figure 81, item E) on top of the outer spacer.
6. Lubricate the remaining upper cone and roller assembly (Figure 81, item F) with oil or grease and slip it over the shaft with the roller radius facing up. Press it onto the shaft and into the upper cup.

NOTE: Make sure all components are aligned before pressing. Press only on the inner cone.

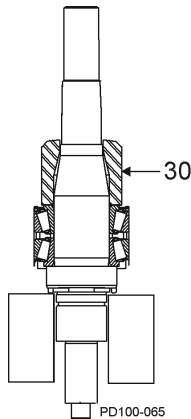

Figure 82 - Install Bearing Spacer

7. Install the bearing spacer (Figure 82, item 30).

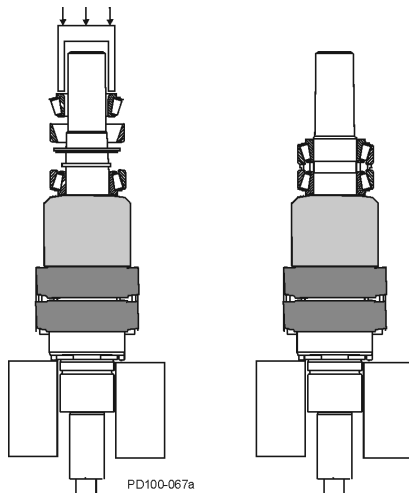

Figure 83 - Rear Tapered Roller Bearing Assembly

Rear Bearing Assembly

Models 006, 014, 015, 018, 024, 030, 033A, 034 use a single ball bearing assembly for the rear bearing. All other models use a tapered roller bearing assembly similar to the front bearings.

1. Unwrap the rear bearing assembly.

NOTE: DO NOT interchange the parts of one bearing assembly with another. These parts are precisely matched during manufacturing and must be installed as a matched assembly.

- **For models with ball bearing assemblies:**
Lubricate the shaft inner bearing race with oil or grease. Press the bearing into place. The shielded side of the bearing fits against the bearing spacer. Press only on the inner race.
- **For models with tapered roller bearing assemblies:**
Lubricate the shaft bearing area with oil or grease. Follow the “Front Bearing Assembly” procedures 35.

NOTE: Heating the bearings is NOT recommended. If bearings are heated, do not exceed 300°F (149°C).

Gear Case Assembly

Shimming

Suggested Shims		
Universal I Model	Std. Shaft	Replacement Shaft
006, 014, 015, 018, 024	0.113 in (2.87 mm)	0.110 in (2.79 mm)
030, 033A, 034, 040	0.105 in (2.27 mm)	0.102 in (2.59 mm)
060, 064, 130, 133A, 134	0.093 in (2.36 mm)	0.088 in (2.24 mm)
220, 223A, 224	0.115 in (2.92 mm)	0.110 in (2.79 mm)
320	0.125 in (3.18 mm)	0.120 i (3.05 mm)

- When installing the shafts in the gear case, shim behind the front bearing to achieve the proper backface clearance between the back of the rotors and the body. The backface clearance must be equal for both rotors to prevent the rotors from hitting each other during operation.

NOTE: Do not install bearing retainer sealant, gears, or gear locknuts until the correct shimming has been verified.

- If the shafts and/or bearings do not need to be replaced and the shims are marked indicating the shaft and bearing they are matched with, a shim adjustment probably will not be necessary. Reuse the existing tagged shims, shafts and bearings in the same gear case bores.
- If existing shims are lost and/or a standard shaft is used, determine the required shims from the chart.
- If it is necessary to calculate the required shims for replacement shafts, bearings or both, refer to Figure 84 and Figure 85; carry measurements and calculations to three decimal places (i.e. 0.059).

NOTE: Arrange with thicker shims on outside of the shim pack.

- Determine the shim thickness required for the front bearing:
 - Measure "B" in the gear case and "C" on the shaft (Figure 84).
 - Measure "D" and "E" on the body (Figure 85).
 - Determine the proper backface clearance. Refer to **Table 4, "Standard Rotor Clearance,"** or Table 5, "Hot Rotor Clearance," on page 42.
 - Required Shims = Backface clearance - C + B + D - E.
- Place the shims in the body, resting against the shoulder in the front bearing bore.

Table 3: Callout table for Figure 84 and Figure 85

B. Front face of gear case to back of bearing bore
C. Shaft shoulder to back of bearing race
D. Body thickness
E. Depth of rotor cavity

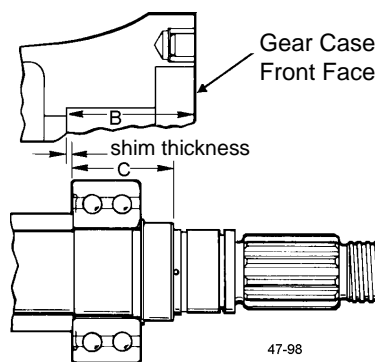

Figure 84 - Measure B and C

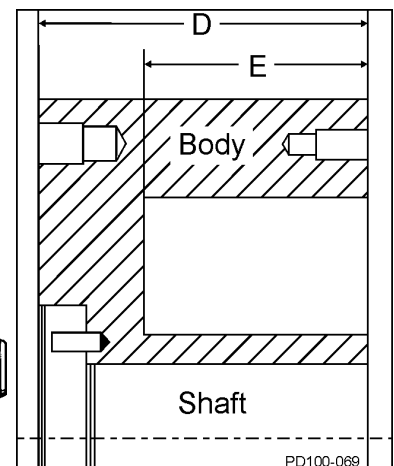

Figure 85 - Measure D and E

Install Shaft

1. With the shims in place, install the shaft assembly in the front bearing bore with the fluid end facing up. Ensure that the shaft is installed in its original location.

NOTE: The shafts may need to be removed for a final shim adjustment.

2. Lubricate the outside diameter of the bearing.
3. Press the shaft into place until it is seated against the shim pack. **Press only against the outer race of the bearing.**

NOTE: A tube of the same diameter as the outer race of the bearing also can be used to press the shaft into place.

4. Temporarily secure the shaft/bearing in place with bearing retainers to aid in checking the clearances. **DO NOT** install silicone sealant at this time.

5. The bearing retainer must rest firmly against the bearing. Leave a 0.010 to 0.050 in (0.25 to 1.25 mm) clearance between the back of the bearing retainer and the front of the gear case (Figure 86). If this clearance is not met, place shims between the bearing and retainer.

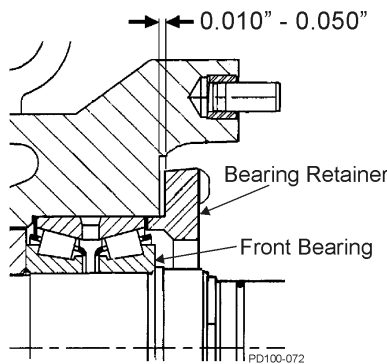

Figure 86 - Bearing Retainer Clearance

6. Temporarily mount the body on the gear case.
7. Secure the body to the gear case using the body retaining screws.
8. Install the rotors and rotor nuts. Rotor nut o-rings, belleville-style washers and retainer o-rings are not required at this time.

9. Measure the rotor backface clearance (Figure 87, item A) through the port or from the front. The backface clearance for both rotors must be the same to prevent rotor crossover contact and must be ± 0.0005 \"/>

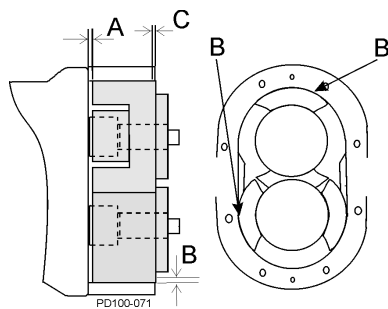

Figure 87 - Measure Clearance

10. Check the rotor front face clearance (Figure 87, item C).
11. Check the rotor to body clearance (Figure 87, item B).
12. Check the clearances against **Table 4, “Standard Rotor Clearance,”** or Table 5, “Hot Rotor Clearance,” on page 42. For other non-standard rotors, check with the factory.

NOTE: “B” dimension is below the face of the casing.

NOTE: If the process uses special clearance rotors, contact WCB with the serial number of the pump for clearance tolerance values.

13. If the backface clearance is not met, disassemble the pump and adjust the shimming to achieve the correct backface clearance.

14. If the rotor to body clearance is not met or is uneven, contact Waukesha Cherry-Burrell technical services for proper adjustment procedures.

15. After obtaining proper clearance, remove the rotor nuts, rotors, body, and bearing retainers.

16. Grease the front and rear bearing through the grease fittings until grease is visible around the bearing assemblies. The amount of grease required is listed in "Grease Quantity (per Bearing)" on page 20. Rotate the shafts while greasing to disperse the grease.

17. Lubricate the seal lips and install the grease seals in the bearing retainers (compression spring on inside).

18. Coat the retainer flanges with silicone sealant (Figure 88, item A). (Gore-Tex® sealing tape can be used on silicone free models.) The grease seal (item 14) will be flush with the front of the bearing retainer. On 030 models, the grease seal will be against the step on the inside diameter of the retainer.

19. Install the bearing retainers (Figure 88, item 32).

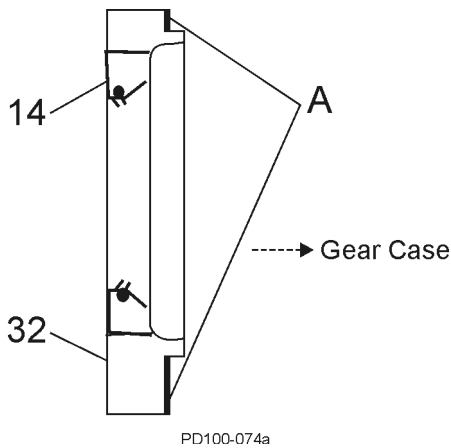

Figure 88 - Install Bearing Retainer

Install Rear Seal Assembly

NOTE: Place tape or other material over the shaft end to prevent cutting the seal during installation.

1. Install the gear spacers (Figure 89, item 29).
2. Lubricate the inside and outside diameters of the oil seals with oil or grease.
3. Install the oil seals with the spring facing out (Figure 89, item 13).

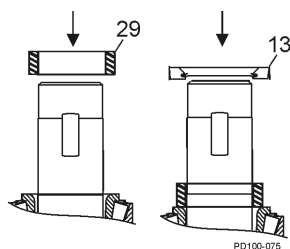

Figure 89 - Install Rear Seal

Install Timing Gears

1. Place the gear keys into the shaft key slots. Angle the keys out for easier installation of the gears.

NOTE: To aid in timing setup, rotate the rotors until they are at right angles to each other before installing the gears.

2. Slide the spur drive gear onto the drive shaft. The spur drive gear has one punch mark on the gear.
3. Slide the short shaft gear onto the short shaft. The short shaft gear has two punch marks on the gear. Straddle the single punch mark of the spur drive gear with the two punch marks on the short shaft gear (Figure 90).

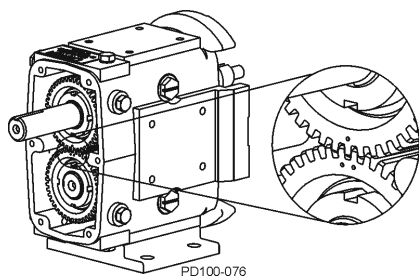

Figure 90 - Timing Gear Marks

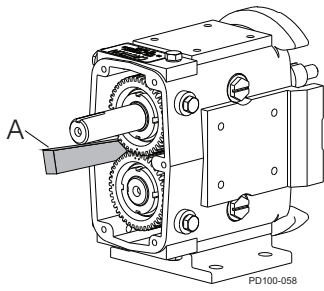

Figure 91 - Block Shaft Rotation

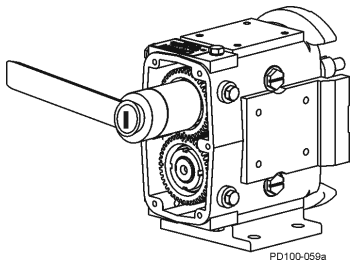

Figure 92 - Install Gear Locknuts

4. Use a wood or nylon block (Figure 91, item A) to keep the shafts from turning. If a block is not available, use rags to block the gears, or with one rotor on the shaft, block the rotor with a nylon dowel.
5. Slide the lock washers onto the shaft. Lubricate the threaded area on the shafts and face of the locknuts with oil or grease.
6. Tighten the gear locknuts using a spanner wrench or drift.
7. Bend the locking tab (Figure 93, item A) on the lock washers into the locking nut slots, securing the gear locknut into place.

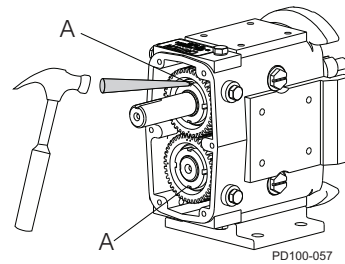

Figure 93 - Bend Lock Tab on Lock washers

Checking for Proper Clearance

Waukesha Cherry-Burrell pumps are designed with close running clearances. Backface clearances are set with shims during assembly.

Shafts are positioned with shims behind the front bearing and locked into gear case with the bearing retainers. Rotors lock against the shaft shoulder. Clearance between the body backface and the back of the rotor wing is called backface clearance.

NOTE: It is good practice to keep backface clearance to a minimum.



CAUTION: Backface clearance for both rotors must be equal to avoid crossover interference with the adjacent rotor hub.

1. To check backface clearance, first mount the body (less seals) onto the housing. Assemble the rotors and secure them with rotor jam nuts.
2. With feeler gauges, measure the rotor backface clearance (Figure 94, item A), through the port or from the front.

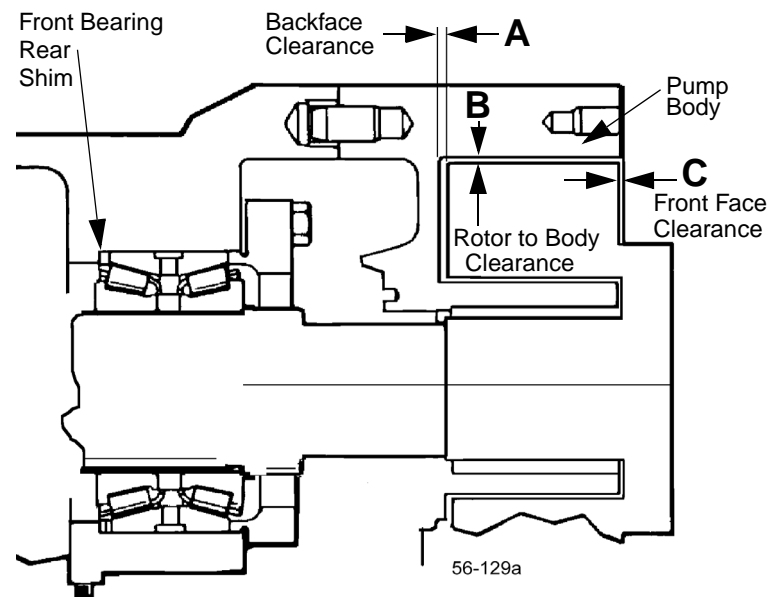

Figure 94 - Clearance Measurements

3. Measure the rotor front face clearance (Figure 94, item C).
4. Measure the rotor to body clearance (Figure 94, item B).
5. Check the measured clearances against **Table 4, "Standard Rotor Clearance,"** or Table 5, "Hot Rotor Clearance," on page 42.
6. Make corrections as required and follow examples in Table 6, "Backface Clearance Corrections," below, to determine the exact adjustment to make and to avoid unnecessary assembly/disassembly.
7. To make shim adjustments, first remove the rotors, body and shafts. Make the required shim adjustment and reassemble.
8. Re-check the backface clearances. Be sure both rotors have the same clearance to avoid crossover interference with the adjacent rotor hub.

Table 4: Standard Rotor Clearance

Universal I Model	A Back Face	B Rotor to Body	C Front Face
006, 014, 015, 018, 024	0.002 in (0.05 mm)	0.002 - 0.003 in (0.05 - 0.08 mm)	0.004 - 0.0065 in (0.10 - 0.17 mm)
030, 033A, 034, 040	0.002 in (0.05 mm)	0.002 - 0.004 in (0.05 - 0.10 mm)	0.0035 - 0.006 in (0.09 - 0.15 mm)
060, 064, 133A, 130, 134	0.003 - 0.0035 in (0.08 - 0.09 mm)	0.004 - 0.0065 in (0.10 - 0.17 mm)	0.0045 - 0.009 in (0.11 - 0.23 mm)
220, 223A, 224	0.004 - 0.005 in (0.10 - 0.13 mm)	0.0065 - 0.0085 in (0.17 - 0.22 mm)	0.005 - 0.010 in (0.13 - 0.25 mm)
320, 323A, 324	0.005 - 0.006 in (0.13 - 0.15 mm)	0.009 - 0.011 in (0.23 - 0.28 mm)	0.007 - 0.012 in (0.18 - 0.30 mm)

NOTE: Clearances listed are for standard rotors. Standard Rotors: -40°F (-40°C) to 200°F (93°C); Hot Clearance Rotors: -40°F (-40°C) to 300°F (149°C). Contact Waukesha Cherry-Burrell Application Engineering if alternate rotors are needed.

Table 5: Hot Rotor Clearance

Universal I Model	A Back Face	B Rotor to Body	C Front Face
006, 014, 015, 018, 024	0.002 in (0.05 mm)	0.0035 - 0.0045 in (0.09 - 0.11 mm)	0.006 - 0.008 in (0.15 - 0.20 mm)
030, 033A, 034, 040	0.002 in (0.05 mm)	0.0035 - 0.005 in (0.09 - 0.13 mm)	0.0065 - 0.009 in (0.17 - 0.23 mm)
060, 064, 133A, 130, 134	0.003 - 0.0035 in (0.08 - 0.09 mm)	0.006 - 0.009 in (0.15 - 0.23 mm)	0.0085 - 0.015 in (0.22 - 0.38 mm)
220, 223A, 224	0.004 - 0.005 in (0.10 - 0.13 mm)	0.010 - 0.012 in (0.25 - 0.30 mm)	0.010 - 0.015 in (0.25 - 0.38 mm)
320, 323A, 324	0.005 - 0.006 in (0.13 - 0.15 mm)	0.011 - 0.013 in (0.28 - 0.33 mm)	0.013 - 0.018 in (0.33 - 0.46 mm)

NOTE: Clearances listed are for hot clearance rotors. Standard Rotors: -40°F (-40°C) to 200°F (93°C); Hot Clearance Rotors: -40°F (-40°C) to 300°F (149°C). Contact Waukesha Cherry-Burrell Application Engineering if alternate rotors are needed.

Table 6: Backface Clearance Corrections

Problem	Condition	Correction
Too Much Backface Clearance (A)	Dimension A is greater than the value in Table 4 (standard rotors) or Table 5 (hot clearance rotors)	A (measured) minus Column A (Table 4 or Table 5) = shims to remove from the rear outer race of the front bearing
	Rotor wing face projects past the body front face	C (measured with depth micrometer) plus C (Table 4 or Table 5) = shims to remove from the rear of the front bearing
Not Enough Backface Clearance (A)	Dimension A is less than the value in Table 4 (standard rotors) or Table 5 (hot clearance rotors)	Column A (Table 4 or Table 5) minus A (measured) = shims to add to the rear outer race of the front bearing

NOTE: If the clearance corrections in Table 6 have been performed and desired performance is not achieved, contact Waukesha Cherry-Burrell technical services for guidance.

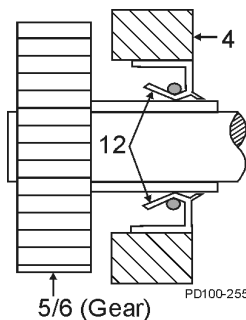

Figure 95 - Orientation of Oil Seal

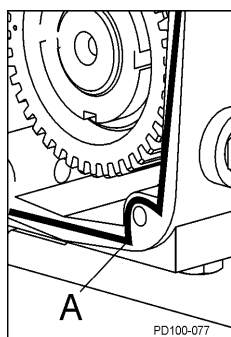

Figure 96 Sealant Placement

Install Gear Case Cover

1. Lubricate the inside diameter of a new oil seal.
2. Press the new oil seal (Figure 95, item 12) into the gear case cover (item 4) flush with the outside face, with the spring facing in.
3. Apply silicone sealant to the back of the gear case. (Gore-Tex[®] sealing tape can be used on silicone-free models.) Place tape on the inside of the screw holes. (Figure 96, item A).
4. Tape the shaft end to prevent cutting the seal on the keyway. Mount the cover assembly on the gear case. Secure it with cap screws and washers.
5. Remove the tape from the shaft end.

NOTE: Make sure that the shaft is centered in the lip seal before securing the cap screws.

6. Install the oil drain plug.
7. Fill gear case with gear oil to proper level. Refer to "Lubrication" on page 20.

Fluid Head Assembly

Seal Assembly: See "Seal Maintenance" on page 27.

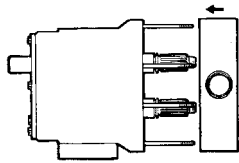

Figure 97 - Slide Body over Shafts

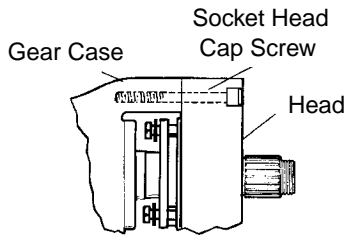

Figure 98 - Model 320, 323A and 324

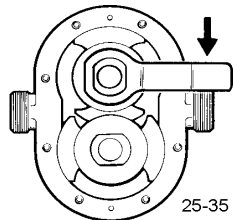

Figure 99 - Rotor Assembly

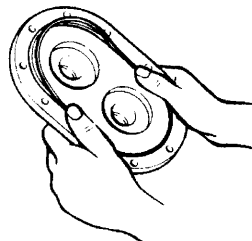

Figure 100 - Cover Assembly

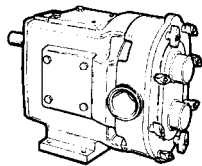

Figure 101 - Attach Wing Nuts

Body Assembly

1. Slide the body over the shafts and studs, taking care that the seal components are not nicked or knocked out of place. Press the body firmly against gear case, engaging the dowels.
2. **On Model 320, 323A and 324**, the bodies are secured to the gearcase with 2 socket head cap screws through the head. See "Seal Maintenance" on page 27.

Rotor Assembly

Assemble a rotor onto the shaft, engaging the large spline tooth with the large groove in the rotor. Rotate the shaft until the rotor wings are on a vertical centerline. Install the second rotor and secure both with rotor retaining nuts (clockwise). Lock the nuts. (See Table 8, "Torque Values and Wrench Size," on page 48).

Cover Assembly

1. Install the o-ring in the cover groove.
2. Mount the cover on the studs and push it against the body, making sure that the o-ring remains in the groove.
3. Attach the wing nuts (clockwise) and tighten by hitting them sharply with a soft hammer.

CAUTION: SPX does not recommend using a vented cover on liquids with a viscosity of over 5000 cPs.

Relief Cover Option (Vented Cover)

The optional Relief Cover Feature (also called Vented Cover) is an adjustable, internal by-pass arrangement which can be used for control of the pressure and/or flow. It is bidirectional; that is, the pump flow or rotation can be in either direction.

This option does not provide full flow relief for all pumping situations.

The pressure downstream of the pump may increase with increasing amount of by-pass through the Relief Cover. Actual downstream pressure will depend on the pump speed, product viscosity, and the relief set point (spring adjustment or air pressure). Avoid high flow rates through the cover with high viscosity products. The resulting pressure may be greater than the maximum rating of the pump or other system components. Install a pressure gauge and measure the pressure under the worst conditions of maximum flow and maximum viscosity to determine the maximum pressure for your process. **Under any conditions, if there is a complete flow shut off downstream, stop the pump as soon as possible.** Continued pump operation with the entire flow by-passing will rapidly build heat within the pump body. Contact Waukesha Application Engineering for assistance.

Three types of Relief Covers are available:

Manual

By-pass pressure is adjusted by a threaded adjusting screw (2) which compresses a spring (5). Several spring sizes are available, to cover a range of operating pressures.

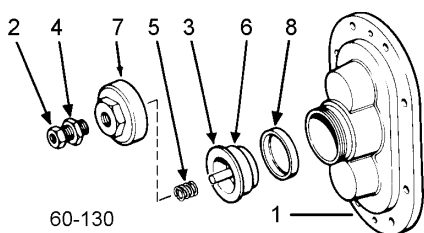

Figure 102 - Manual Vented Cover

Pneumatic

By-pass pressure is adjusted by regulated air or gas pressure, operating on the side of a diaphragm (9) opposite the pumped fluid.

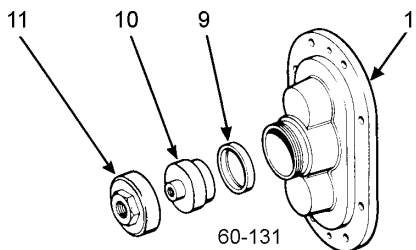

Figure 103 - Pneumatic Vented Cover

Piston

By-pass pressure is adjusted by regulated air or gas pressure, operating on the side of a metal piston (12), opposite the pumped fluid. An extended pressure range is possible.

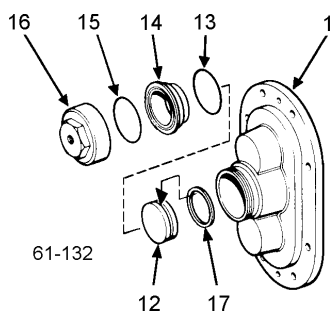
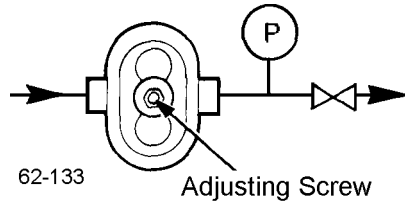

Figure 104 - Piston Vented Cover

NOTE: On all types of relief covers, the temperature and chemical resistance of the elastomer diaphragms and O-rings determine the useful range:

Buna-N: Material supplied as standard

Silicone Rubber: Optional material upon request



62-133

Adjusting Screw

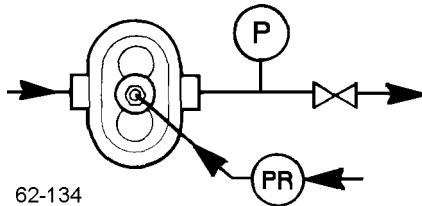
Figure 105 - Manual Adjustment

62-134

Figure 106 - Adjustment with a Pressure Gauge

Installation Adjustment

Manual

Turn the adjusting screw counterclockwise to its farthest position, then clockwise until a light spring pressure is felt.

Pneumatic

1. Set air/gas pressure to 2-5 psig.
2. Turn on the pump.
 - A. With the pressure gauge and valve in the discharge line:
 - Close the discharge valve.
 - Turn the adjusting screw clockwise until the desired relief pressure registers on the gauge. Lock the adjusting screw with a lock nut.
 - Open the valve in the discharge line. The relief cover is set and will open if the system pressure exceeds the preset limit.
 - B. Without a pressure gauge in the discharge line:
 - Turn the adjusting screw clockwise and observe the product flow at the discharge of the system.

When the product flow reaches the maximum or desired flow rate, lock the adjusting screw with a lock nut.

Piston

1. With a pressure gauge and valve in the discharge line:
 - Close the discharge valve slowly and observe the gauge pressure. **DO NOT ALLOW PRESSURE TO EXCEED 200 psi.**
 - Increase the air/gas pressure, until the desired relief pressure registers on the gauge. Lock the air/gas pressure regulator adjusting screw with a lock nut.
 - Open the valve in the discharge line. The relief cover is set and will open if the system pressure exceeds the preset limit.
2. Without a pressure gauge in the discharge line:
 - With a regulator, increase the air/gas pressure to the relief valve and observe the product flow at the discharge of the system.

When the product flow reaches a maximum or desired flow rate, lock the regulator adjusting screw with a lock nut.

Jacketed Cover

Available on Models 006, 015, 018, 030, 040, 060, 130, and 220.

The jacketed cover is designed to allow circulation of a heating or cooling medium. The purpose is to help preheat or cool the pumping head and sustain operating temperature during short shut down periods. It should not be used as a heat exchanger to control pumping temperature during operation.

NOTE: Pressure limit for cover media is 60 PSI.

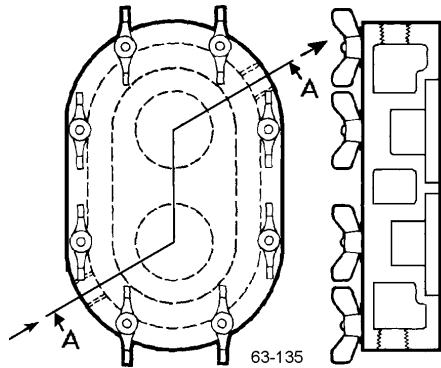

Figure 107 - Jacketed Cover

Table 7: Pipe Tap

Model Number	Pipe Tap
006, 015, 018, 030, 040	3/4"
060, 130, 220	1"

Pump Jackets

Split cast aluminum jackets with cast in pipe passages are available for higher pressures and temperatures. Consult factory for recommendations.

NOTE: Jacketed pumps require longer mounting studs in the gearcase. Use a special offset rotor wrench to remove rotors from 006 through 060 models to avoid hitting the studs. For part numbers, see "Offset Rotor Wrench" on page 91.

Flushing Connection

NOTE: Flushing media may be piped into either side for both shaft seals and discharged to drain on opposite side. Both inlets may be manifolded to simplify piping. Be sure flush water is flowing out both discharge lines.

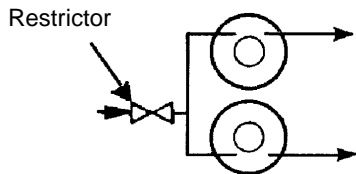

Figure 108 - Low Pressure Flush

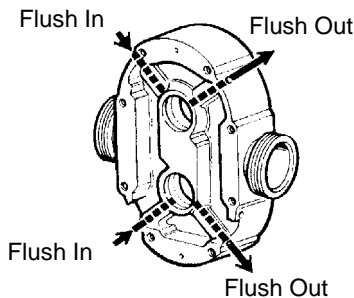

Figure 109 - Flushing Connections

Low Pressure Flush

1. Set flow rate of approximately 1/4 GPM for most applications. For high temperature applications increase flow.
2. Flushing media is restricted on inlet side and has free flow to drain on outlet side.
3. Typical flushing connections are 1/8" NPT female pipe taps.

Flushing Connection - Aseptic Series

All connections are 1/8" female pipe taps. The pump has double "barriers" or seals at every opening to the pump chamber. Live steam or a sterile fluid is circulated between these double seals at the ports, in the cover and at the shaft seals.

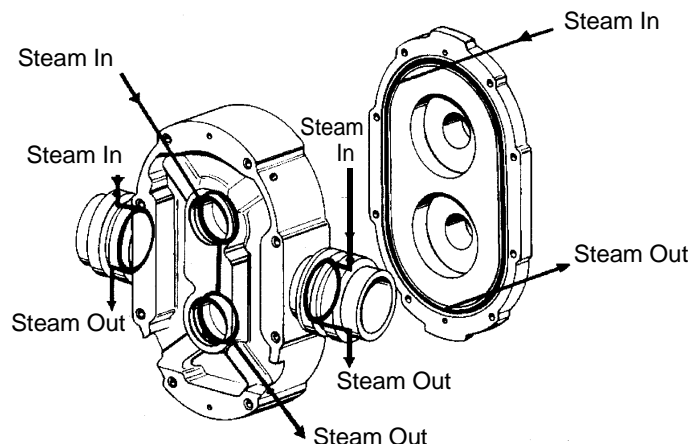

Figure 110 - Flushing Connection - Aseptic Series

Reference Tables

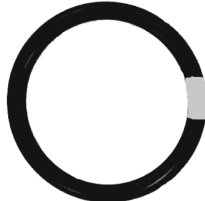

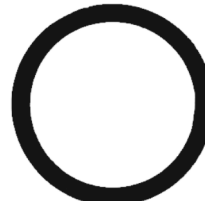



Table 8: Torque Values and Wrench Size

Universal I Model	Torque Values - Lock Nuts			Wrench Size
	Bearing	Gear	Rotor	Body Retaining Cap Screw
006, 014, 015, 018, 024	--	75 ft lbs 102 N·m	30 ft lbs 41 N·m	3/16"
030, 033A, 034, 040	--	100 ft lbs 136 N·m	60 ft lbs 81 N·m	
060, 064, 130, 133A, 134	150 ft lbs 203 N·m	140 ft lbs 190 N·m	75ft lbs 102 N·m	1/4"
220, 223A, 224	240 ft lbs 325 N·m	230 ft lbs 312 N·m	150 ft lbs 203 N·m	5/16"
320, 323A, 324	360 ft lbs 488 N·m	320 ft lbs 434 N·m	190 ft lbs 258 N·m	

Table 9: Arbor or Hydraulic Press Required (Tons)

Universal I Model	Shaft		Front Bearing		Rear Bearings			
					Housing		Shaft	
	In	Out	On	Off	In	Out	On	Off
006, 014, 015, 018, 024	0.25	0.5	0.5	1	0.5	1		
014, 015, 018, 030, 033A, 034, 040	0.25	0.5	0.5	1	0.5	1		
060, 064, 130, 133A, 134	0.5	1	2	5			3	5
220, 223A, 224	0.5	1	5	15			5	15
320, 323A, 324	0.5	1	5	20			5	20

Standard WCB O-Ring Selections, Descriptions and Color Codes

<p>Nitrile (Buna-N) (NBR) Compound Color: Black Color Code: Yellow FDA Compliant to 21CFR177.2600 3A Sanitary</p>		<p>Silicone (Si) Compound Color: Orange Color Code: Black FDA Compliant to 21CFR177.2600 3A Sanitary</p>	
<p>Ethylene Propylene Diene Rubber (EPDM) Compound Color: Black or Purple Color Code: Green FDA Compliant to 21CFR177.2600</p>		<p>Perfluoroelastomer (FFKM) Compound Color: Black Color Code: None Individually packaged with size and material noted.</p>	
<p>Ethylene Propylene Diene Rubber (Sulfur Free) (EPDM) Compound Color: Black or Purple Color Code: Blue FDA Compliant to 21CFR177.2600</p>		<p>PTFE Encapsulated Compound Color: Translucent coating over Orange or Black Silicone or FKM core Color Code: None FDA Compliant to 21CFR177.2600</p>	
<p>Fluorocarbon Rubber (FKM) Compound Color: Rust, Brown or Black Color Code: White FDA Compliant to 21CFR177.2600 3A Sanitary</p>			

Parts Lists

006-014-015-018-024-UI Pump Parts

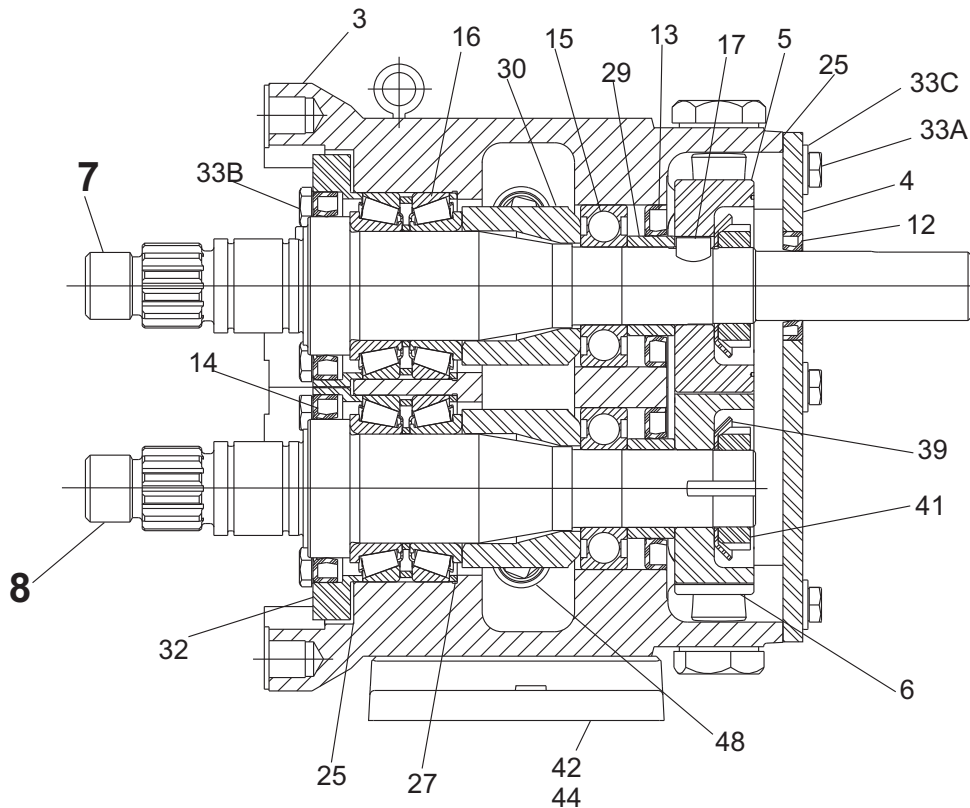
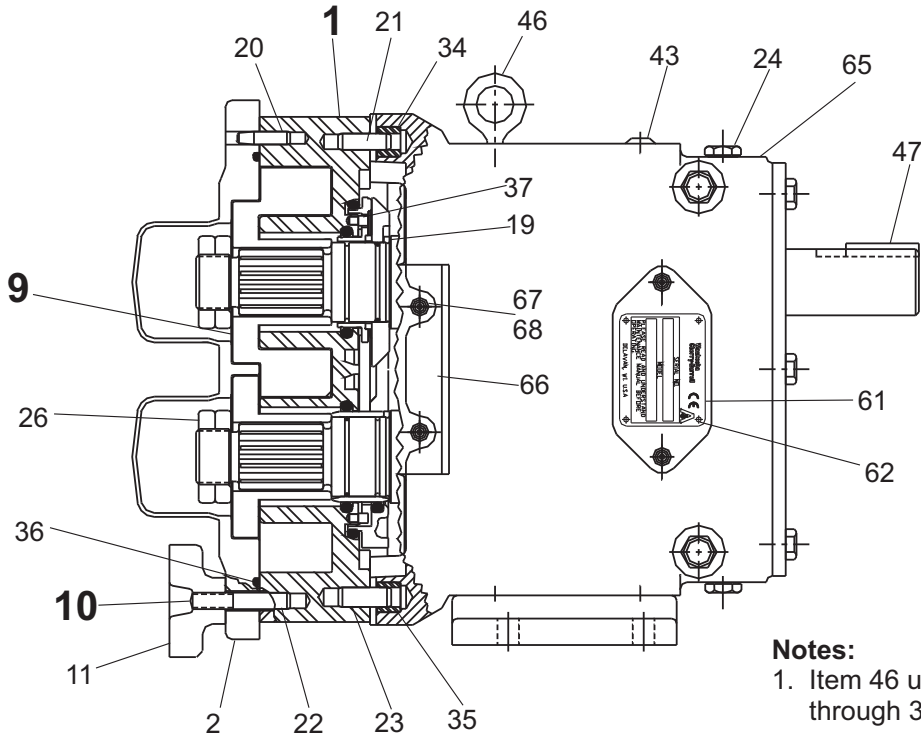

PD100-308

006-014-015-018-024-UI Pump Parts

ITEM NO.	DESCRIPTION	QTY. PER PUMP	PART NO.	NOTES
	Pump Body	1	See Note 1	1
7	006-014-015-U1 Drive Shaft	1	015 008 000+	3
	006-014-015-U1 Drive Shaft	1	114642+	4
	018-024-U1 Drive Shaft	1	018 008 000+	3
	018-024-U1 Drive Shaft	1	114644+	4
8	006-014-015-U1 Short Shaft	1	015 009 000+	3
	006-014-015-U1 Short Shaft	1	114643+	4
	018-024-U1 Short Shaft	1	018 009 000+	3
	018-024-U1 Short Shaft	1	114645+	4
9	006-U1 Rotor, Twin Wing, Alloy 88	2	006 010 000+	2
	006-U1 Rotor, Twin Wing, 316SS	2	006 010 200+	2
	006-U1 Rotor, Single Wing, Alloy 88	2	117238+	2, 12
	014-015-U1 Rotor, Twin Wing, Alloy 88	2	015 010 000+	2
	014-015-U1 Rotor, Twin Wing, 316SS	2	015 010 200+	2
	015-U1 Rotor, Single Wing, Alloy 88	2	117255+	2, 12a, 13
	018-024-U1 Rotor, Twin Wing, Alloy 88	2	018 010 000+	2
	018-024-U1 Rotor, Twin Wing, 316SS	2	018 010 200+	2
	018-U1 Rotor, Single Wing, Alloy 88	2	117273+	2, 12b, 13
10A	006-015-U1 Stud	8	AD0 011 000	
10B	006-015-U1 Stud, Jacketed Cover	8	AD0 011 J00	
10C	014-U1 Stud	6	AD0 011 000	
	014-U1 Stud	2	35547+	
10D	014-U1 Stud, Jacketed Cover	6	AD0 011 J00	
	014-U1 Stud, Jacketed Cover	2	35548+	
10E	018-U1 Stud	8	018 011 000+	
10F	018-U1 Stud, Jacketed Cover	8	AD0 011 100	
10G	024-U1 Stud	6	018 011 000+	
	024-U1 Stud	2	35547+	
10H	024-U1 Stud, Jacketed Cover	6	AD0 011 100	
	024-U1 Stud, Jacketed Cover	2	35548+	
	Stud Retainer Assembly	1	020 064 000+	5

NOTES:

PL5060-CH31

1. Contact Factory with Serial Number of pump for Part Number.
2. Standard clearances and finishes for Rotor Part Numbers shown. Contact Factory for optional clearances and finishes.
3. Pumps shipped prior to July 30, 2001.
4. Pumps shipped starting July 30, 2001.
5. No longer manufactured, consult factory for upgrade of gear case subassembly.
12. Replaces 006 010 010 straight and 006 010 090 90° (degree) rotors.
- 12a. Replaces 015 010 010 straight and 015 010 090 90° (degree) rotors.
- 12b. Replaces 018 010 010 straight and 018 010 090 90° (degree) rotors.
13. Single wing rotors can not be used in Rectangular Flange Inlet pumps.

006-014-015-018-024-UI Common Parts

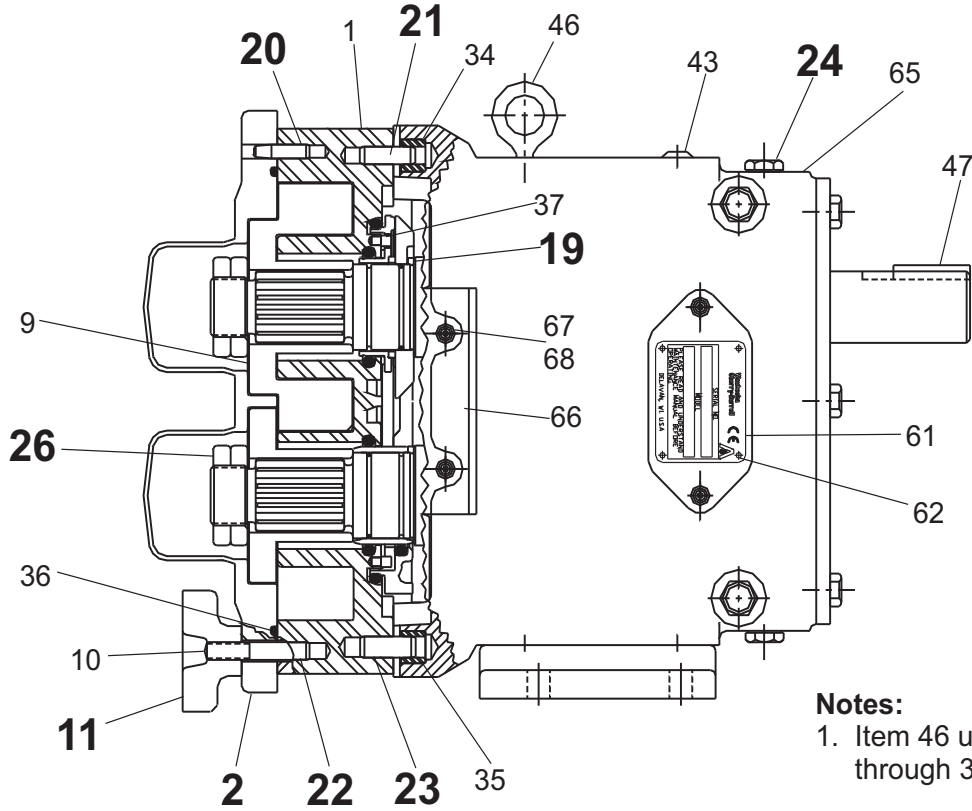

Notes:
 1. Item 46 used on 60 through 320.

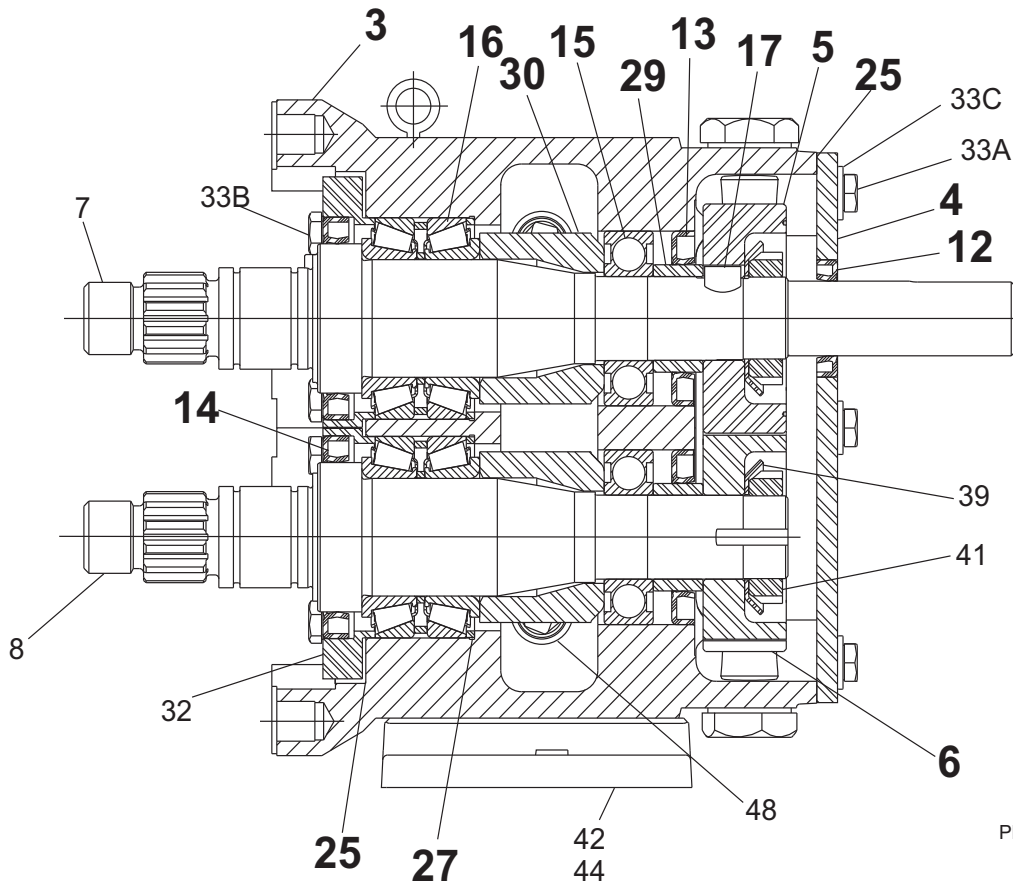

PD100-309

See also "Grease Seal, Bearing Retainer, O-Ring Seal Carrier Part Number Reference" on page 91.

006-014-015-018-024-UI Common Parts

ITEM NO.	DESCRIPTION	QTY. PER PUMP	PART NO.	NOTES
2	Pump Cover	1	AD0 002 S00	
	Jacketed Cover	1	AD0 002 J10	
	Pump Cover Vented - Complete Assembly			
	Manual (over 150 PSI)	1	CVR00027	
	Manual (under 150 PSI)	1	CVR00006	
	Pneumatic	1	CVR00004	
	Piston	1	CVR00005	
3	006-015-U1 Gear Case Assembly, CI	1	115231-C	9
	006-015-U1 Gear Case Assembly, SS (Optional)	1	115243-C	9
	014-U1 Gear Case Assembly, CI	1	115467-C	9
	014-U1 Gear Case Assembly, SS (Optional)	1	115479-C	9
	018-U1 Gear Case Assembly, CI	1	115233-C	9
	018-U1 Gear Case Assembly, SS (Optional)	1	115245-C	9
	024-U1 Gear Case Assembly, CI	1	115469-C	9
	024-U1 Gear Case Assembly, SS (Optional)	1	115481-C	9
4	Gear Case Cover, Steel	1	020 106 000+	
	Gear Case Cover, SS; Optional	1	102280+	
5	Gear, Drive Shaft, Spur	1	107997+	
6	Gear, Short Shaft, Spur	1	107997+	
11	Wing Nut	8	105850+	
	Hex Nut, optional	8	108369+	
12	Oil Seal, Gear Case Cover	1	000 030 016+	
13	Oil Seal, Gear Case Rear	2	000 030 017+	
14	Grease Seal, Bearing Retainer	2	121679+	7
	Bearing Isolator Kit, includes Bearing Retainer	1	X06638-1	4
15	Bearing, Rear	2	015 035 000+	
16	Bearing, Front	2	101714+	4
17	Key, Gear	2	015 037 000+	
19	Drive Pin, Seal Seat and Sleeve	2	CD0 126 000	
20	Dowel Pin, Upper Cover Side	1	AD0 040 000	
21	Dowel Pin, Upper Gear Case Side	1	AD0 040 R00	
22	Dowel Pin, Lower Cover Side	1	AD0 040 100	
23	Dowel Pin, Lower Gear Case Side	1	AD0 040 R10	
24	Fill, Drain, Level Plug	6	115798+	8
25	Silicone Sealant	1	000 142 301+	
26	Jam Nut, Rotor	4	AD0 052 001	
27	Shim Kit	2	117889+	4
	Shim, Front Bearing, .002" thick	as req'd	015 054 002+	
	Shim, Front Bearing, .003" thick	as req'd	015 054 003+	
	Shim, Front Bearing, .005" thick	as req'd	015 054 005+	
	Shim, Front Bearing, .010" thick	as req'd	015 054 010+	
	Shim, Front Bearing, .049"-.051" thick	as req'd	015 054 050+	
29	Spacer, Gear to Rear Bearing	2	015 055 000+	
30	Bearing Spacer	2	101814+	4

NOTES:

PL5060-CH32

4. Pumps shipped starting July 30, 2001.
7. Pumps shipped starting June 2004. Bearing retainer part # for 121679+ is 120332+.
8. The old sight glass plug part number was 000046002+. PD pumps changed approximately Oct. 2003. Please verify the date of manufacture of the pump to identify the correct part needed.
9. Pumps shipped starting July 30, 2001. Assembly includes shafts and timing gears.

006-014-015-018-024-UI Common Parts, cont'd

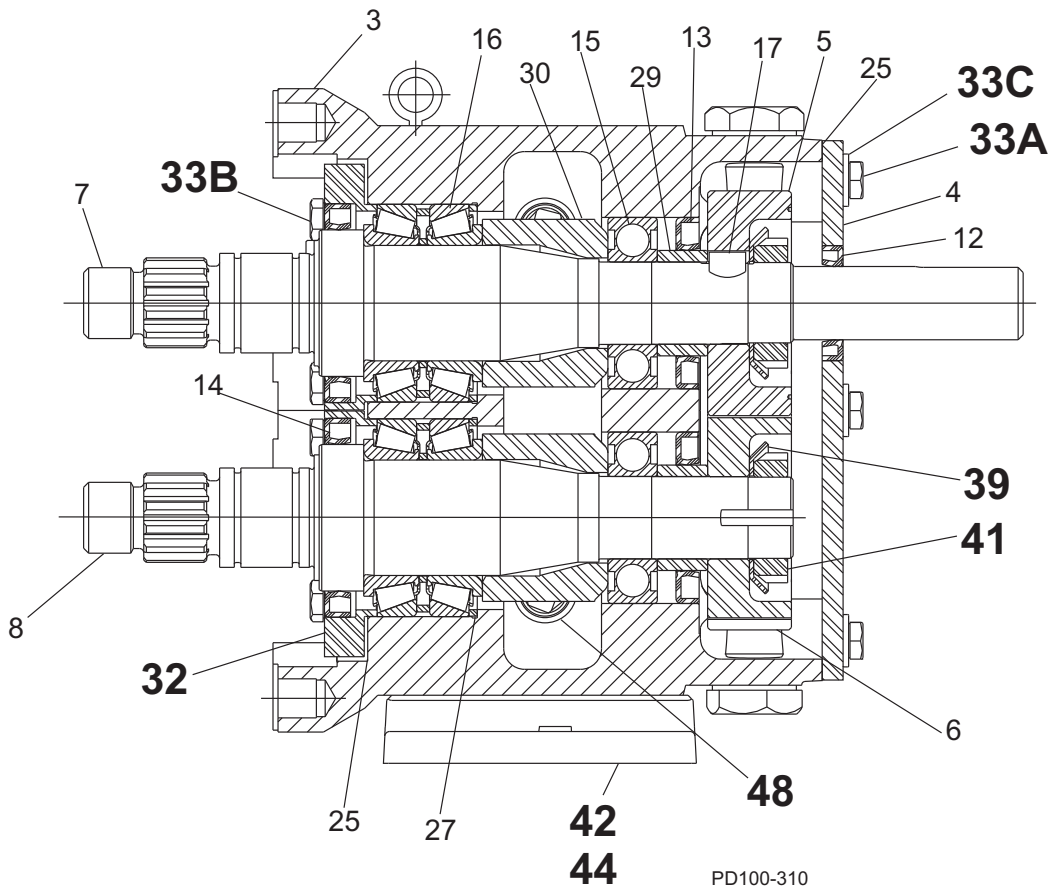
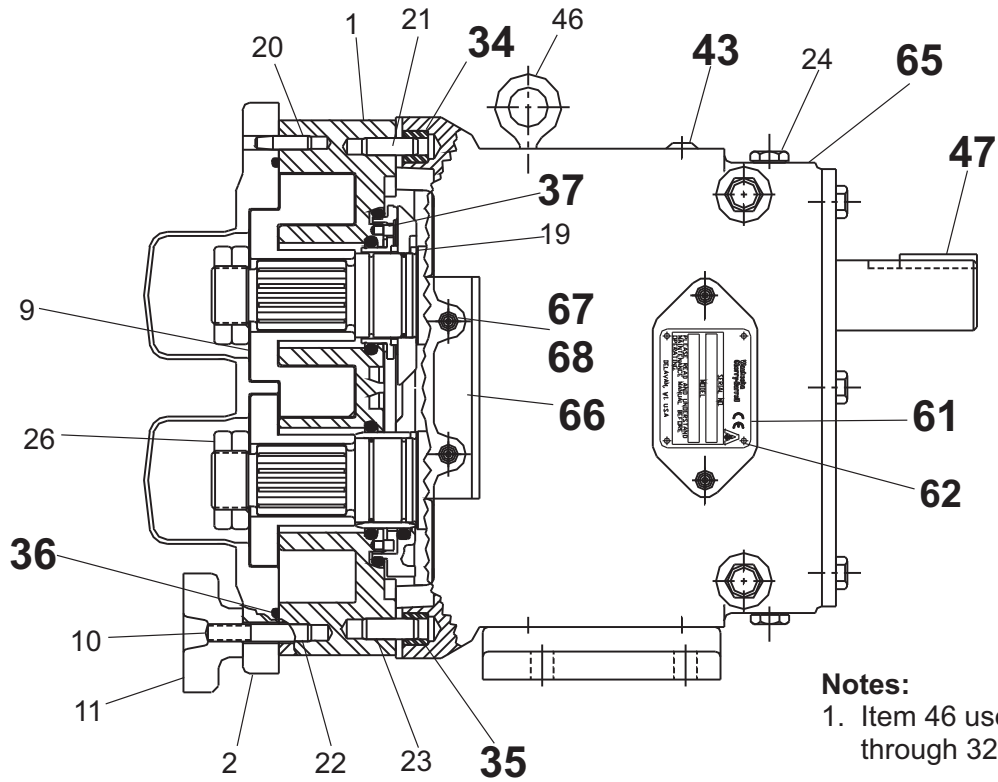

006-014-015-018-024-UI Common Parts, cont'd

ITEM NO.	DESCRIPTION	QTY. PER PUMP	PART NO.	NOTES
32	Bearing Retainer, Front	2	120332+	4, 1
	Bearing Retainer, Front	2	015 080 000+	5, 3
	Bearing Retainer, Front (for SS Gearcase)	2	101810+	4, 2
33A, 33B	1/4-20 x .75" HHCS, Standard	14	30-287	
	1/4-20 x .75" HHCS, SS	14	30-58	
33C	1/4" Flat Washer, Gear Case Cover	6	43-108	
34	Dowel Bushing, Upper	1	AD0 116 000	
35	Dowel Bushing, Lower	1	AD0 116 100	
* * * * * *	O-Ring, Pump Cover, Buna N	1	N70252	
	O-Ring, Pump Cover, EPDM	1	E70252	
	O-Ring, Pump Cover, FKM	1	V70252	
	O-Ring, Pump Cover, Silicone	1	S75251	
* * *	014-U1 O-Ring, Rectangular Flange	1	N70241	
	024-U1 O-Ring, Rectangular Flange	1	N70241	14
	024-U1 O-Ring, Rectangular Flange	1	N70245	14
37	Stop Pin, Seal	2	015 126 000+	
39	Lockwasher, Gear	2	STD 136 005	
41	Locknut, Gear	2	STD 236 005	
42	Gear Case Shim, CI	1	020 110 000+	
	Gear Case Shim, SS; Optional	1	102284+	
	Pump Pedestal, 6.75"; Optional	1	014 110 675+	
43	Plastic Cap Plug	8	000 121 003+	
44	5/16-18 x 1" SHCS, Standard	4	30-343	
	5/16-18 x 1" SHCS, SS	4	30-525	
45	006-014-015-U1 Body Retaining Screw	2	30-523	
	018-024-U1 Body Retaining Screw	2	30-211	
47	Key, Coupling - 3/16 x 3/16 x 1-1/8"	1	000 037 001+	
48	Cleanout Plug	2	35824+	
61	Name Plate, Sanitary	1	001 061 002+	
62	#2 x .125" RHDS	4	30-355	
63	O-Ring Removal Tool	1	AD0 096 001	
64	Rotor Nut Wrench, SS	1	109895+	
	Rotor Nut Wrench, Jacketed Cover	1	AD0 019 001	
65	Caution Plate	2	121694+	
66	Warning Label	2	33-63	
67	006, 015, 018 - U1 Grease Fitting, 1/8" (straight)	4	BD0 092 000	
	014-024-U1 Grease Fitting, 1/8" (angled)	4	BD0 092 100	
68	Plastic Cap, Grease Fitting	4	BD0 093 000	

NOTES:

PL5060-CH33

- Used with seal part # 121679+
- For SS gearcase or bearing isolator; used with seal part # 101716+
- Used with seal part # 000039918+
- Pumps shipped starting July 30, 2001
- Pumps shipped prior to July 30, 2001
14. New O-Rings N70245 (024) introduced in 2001. Fits close to inlet opening.

* Recommended Spare Parts

See also "Grease Seal, Bearing Retainer, O-Ring Seal Carrier Part Number Reference" on page 91.

030-033A-034-040-UI Pump Parts

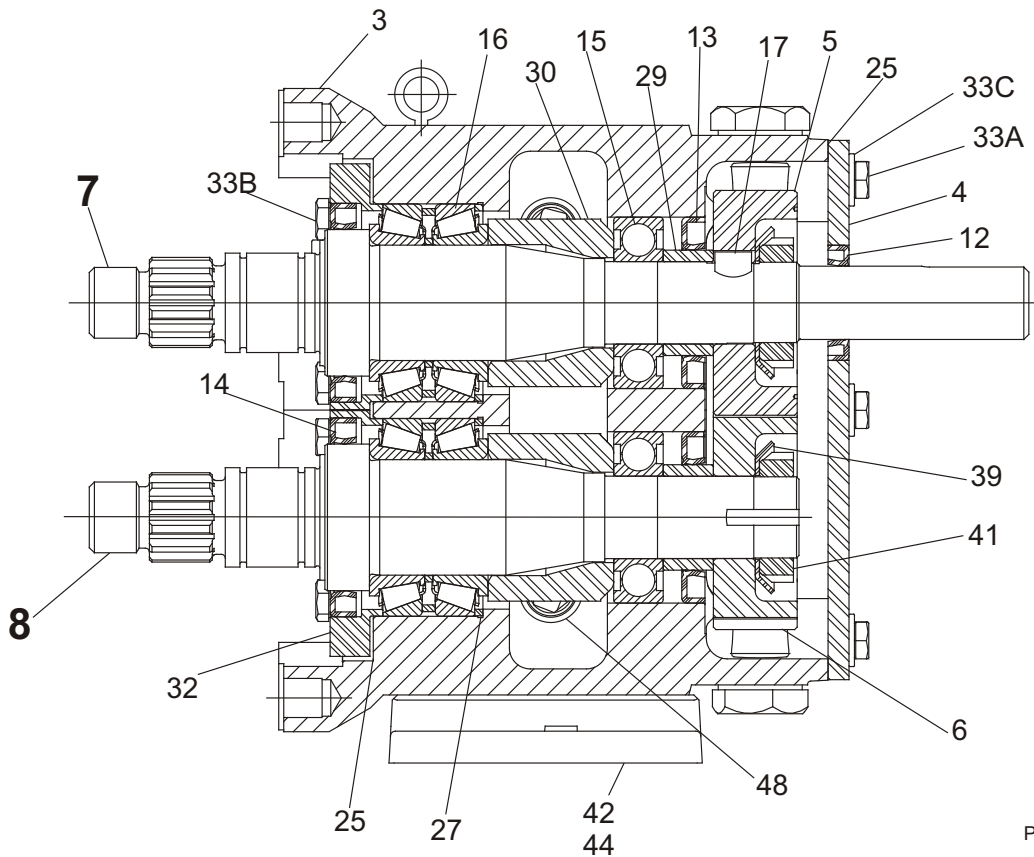
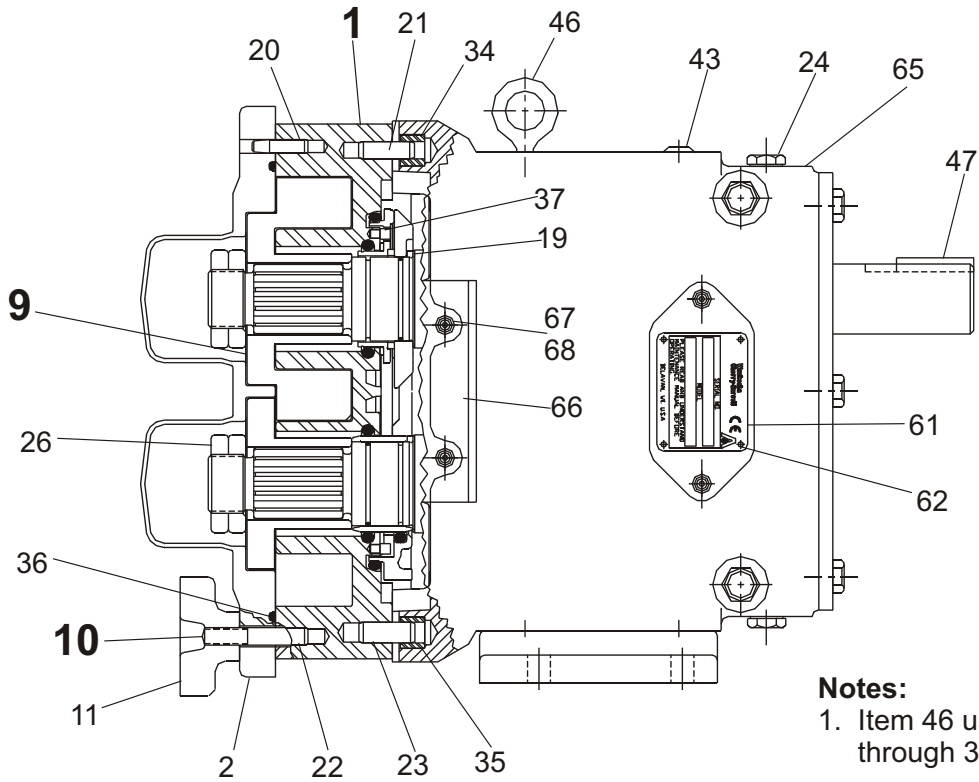

PD100-311

030-033A-034-040-UI Pump Parts

ITEM NO.	DESCRIPTION	QTY. PER PUMP	PART NO.	NOTES
1	030-034-040-UI Pump Body	1	See Note 1	1
	033A-U1 Pump Aseptic Body	1	033 001 020+	
7	030-034-U1 Drive Shaft, Std.	1	030 008 000+	3
	030-034-U1 Drive Shaft, Optional 17-4PH	1	35341+	3
	030-034-U1 Drive Shaft, Std.	1	114646+	4
	030-034-U1 Drive Shaft, Optional 17-4PH	1	114779+	4
	033A-U1 Drive Shaft, Std.	1	033 008 000+	3
	033A-U1 Drive Shaft, Std.	1	114648+	4
	040-U1 Drive Shaft, Std.	1	118718+	
	040-U1 Drive Shaft, Optional 17-4PH	1	118812+	
8	030-034-U1 Short Shaft, Std.	1	030 009 000+	3
	030-034-U1 Short Shaft, Optional 17-4PH	1	35342+	3
	030-034-U1 Short Shaft, Std.	1	114647+	4
	030-034-U1 Short Shaft, Optional 17-4PH	1	114780+	4
	033A-U1 Short Shaft, Std.	1	033 009 000+	3
	033A-U1 Short Shaft, Std.	1	114649+	4
	040-U1 Short Shaft, Std.	1	118719+	
	040-U1 Short Shaft, Optional 17-4PH	1	118813+	
9	030-034-U1 Rotor, Twin Wing, Alloy 88	2	030 010 000+	2
	030-034-U1 Rotor, Twin Wing, 316SS	2	030 010 200+	2
	030-U1 Rotor, Single Wing, Alloy 88	2	117291+	2, 12, 13
	033A-U1 Rotor, Twin Wing, Alloy 88	2	33A 010 000	2
	033A-U1 Rotor, Single Wing, Alloy 88	2	117326+	2, 12A
	040-U1 Rotor, Twin Wing, Alloy 88	2	118728+	2
	040-U1 Rotor, Twin Wing, 316SS	2	118753+	2
	040-U1 Rotor, Single Wing, Alloy 88	2	122711+	2, 13
10A	030-033A-U1 Stud	8	108842+	
10B	030-033A-U1 Stud, Jacketed Cover	8	108845+	
10C	034-U1 Stud	6	108842+	
	034-U1 Stud	2	35555+	
10D	034-U1 Stud, Jacketed Cover	6	108845+	
	034-U1 Stud, Jacketed Cover	2	35549+	
10E	040-U1 Stud	8	118897+	
	040-U1 Stud, Jacketed Cover	8	118898+	
	Stud Retainer Assembly	1	Contact Factory	5

NOTES:

PL5060-CH36a

1. Contact Factory with Serial Number of pump for Part Number.
2. Standard clearances and finishes for Rotor Part Numbers shown. Contact Factory for optional clearances and finishes.
3. Pumps shipped prior to July 30, 2001.
4. Pumps shipped starting July 30, 2001.
5. No longer manufactured, consult factory for upgrade of gear case subassembly.
12. Replaces 030 010 010 straight and 030 010 090 90° (degree) rotors.
- 12A. Replaces 33A 010 010 straight and 33A 010 090 90° (degree) rotors.
13. Single wing rotors cannot be used in Rectangular Flange Inlet pumps.

030-033A-034-040-UI Common Parts

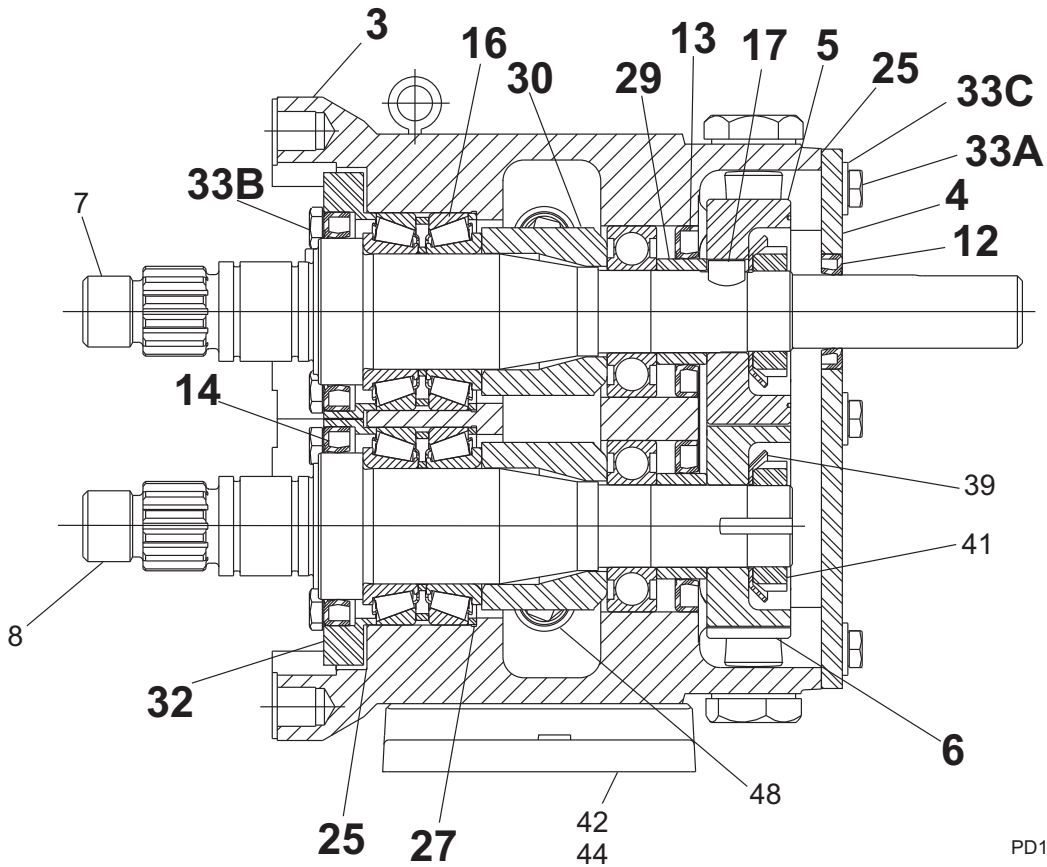
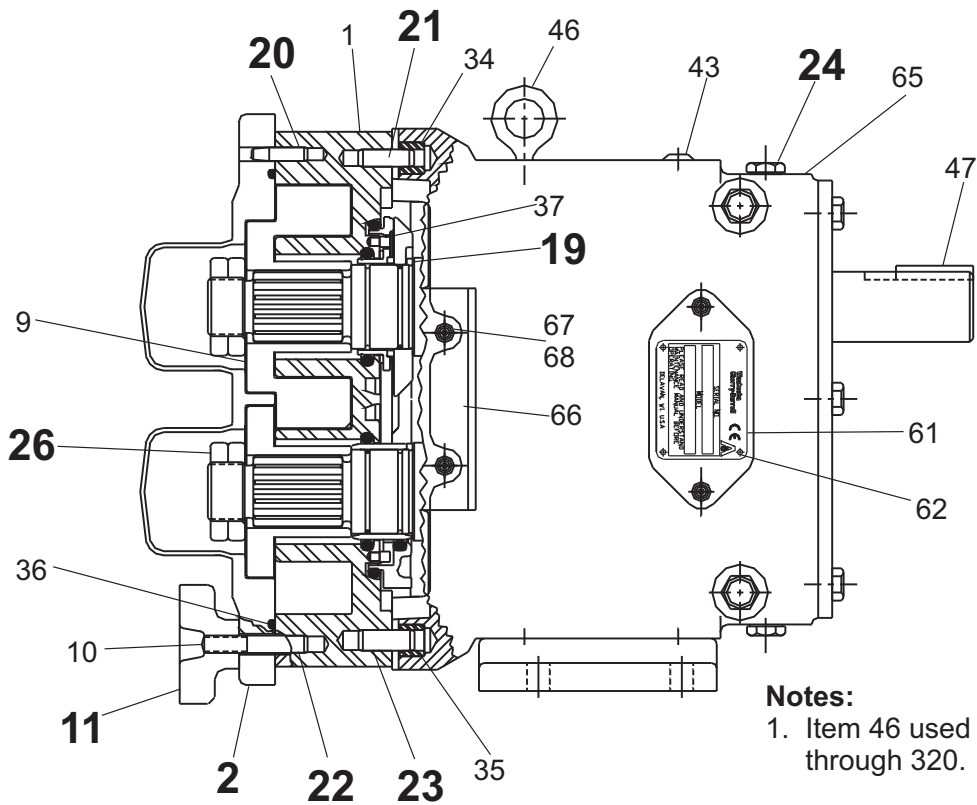

PD100-312

030-033A-034-040-UI Common Parts

ITEM NO.	DESCRIPTION	QTY. PER PUMP	PART NO.	NOTES	
2	030-034-040-UI Pump Cover	1	BD0 002 S00		
	030-034-040-UI Jacketed Cover	1	BD0 002 J10		
	033A-UI Pump Cover	1	33A 002 020		
	Pump Cover Vented - Complete Assembly				
	030-034-040-UI Manual (over 150 PSI)	1	CVR00007		
	030-034-040-UI Manual (under 150 PSI)	1	CVR00014		
	030-034-040-UI Pneumatic	1	CVR00010		
3	030-034-040-UI Piston	1	CVR00022		
	030-UI Gear Case Assembly, CI	1	115235-C	6	
	030-Gear Case Assembly, SS; Optional	1	115247-C	6	
	033A-UI Gear Case Assembly, CI	1	115289-C	6	
	033A-UI Gear Case Assembly, SS; Optional	1	134061-C	6	
	034-UI Gear Case Assembly, CI	1	115471-C	6	
	034-UI Gear Case Assembly, SS; Optional	1	115483-C	6	
	040-UI Gear Case Assembly, CI	1	121660-C	6	
040-UI Gear Case Assembly, SS; Optional	1	124125-C	6		
4	Gear Case Cover, Steel	1	040 106 000+		
	Gear Case Cover, SS; Optional	1	102281+		
5	Gear, Drive Shaft, Spur	1	107999+		
6	Gear, Short Shaft, Spur	1	107999+		
11	Wing Nut	8	105851+		
	Hex Nut, optional	8	108370+		
12	Oil Seal, Gear Case Cover	1	000 030 013+		
13	Oil Seal, Gear Case Rear	2	000 030 014+		
14	Grease Seal, Bearing Retainer	2	121680+		
	Bearing Isolator Kit, includes Bearing Retainer	1	X06639-1	8	
15	Bearing, Rear	2	030 035 000+		
16	Bearing, Front	2	101715+		
17	Key, Gear	2	BD0 037 000		
19	Drive Pin, Seal Seat and Sleeve	2	CD0 126 000		
20	Dowel Pin, Upper Cover Side	1	BD0 040 000		
21	Dowel Pin, Upper Gear Case Side	1	BD0 040 200		
22	Dowel Pin, Lower Cover Side	1	BD0 040 100		
23	Dowel Pin, Lower Gear Case Side	1	BD0 040 300		
24	Hex Capscrew; Fill, Drain, Level	6	115799+		
25	Silicone Sealant	1	000 142 301+		
26	Jam Nut, Rotor	4	BD0 052 001		
27	Shim Kit	2	117890+		
29	Spacer, Gear to Rear Bearing	2	030 055 000+		
30	Bearing Spacer	2	101815+		
32	Bearing Retainer, Front	2	120333+		

NOTES:

PL5060-CH37a

6. Gear case assembly includes timing gears and 316SS shafts. SS gearcase assy includes 316LSS bearing retainer.
8. X06639-1 includes bearing retainer 122337+ (std for pumps manuf. after July 2004).

See also "Grease Seal, Bearing Retainer, O-Ring Seal Carrier Part Number Reference" on page 91.

030-033A-034-040-UI Common Parts, cont'd

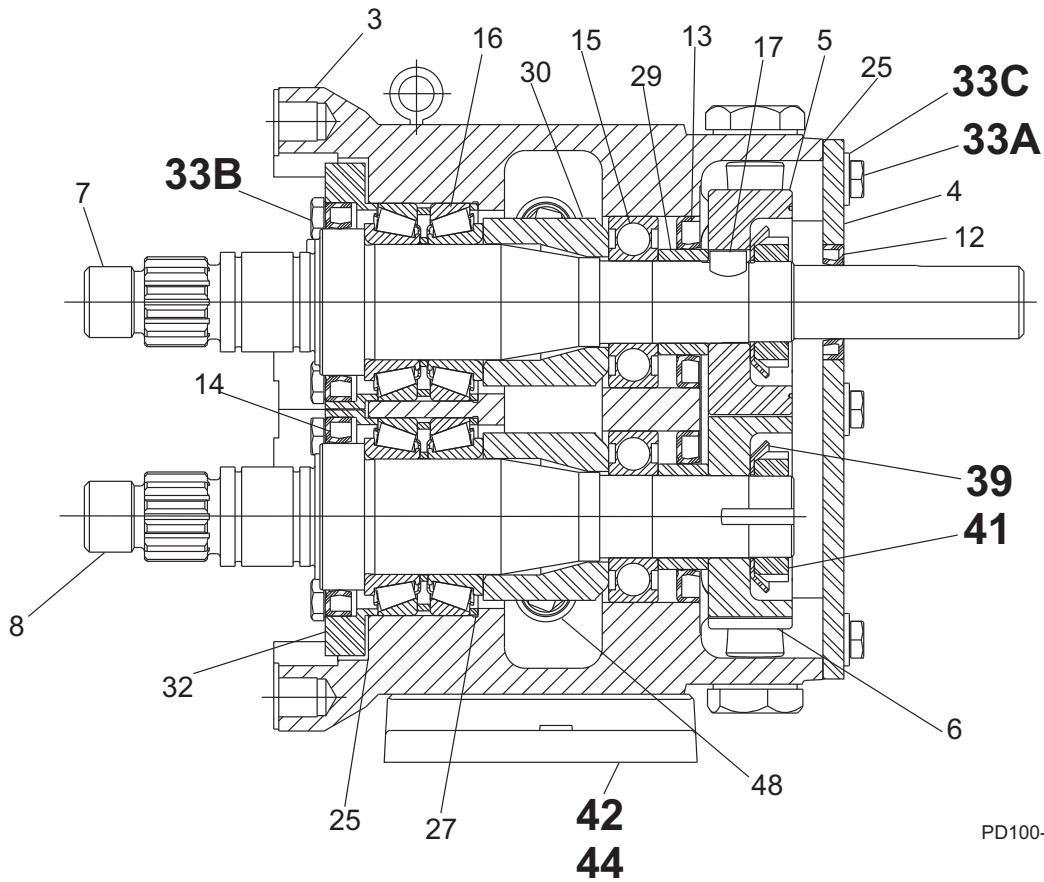
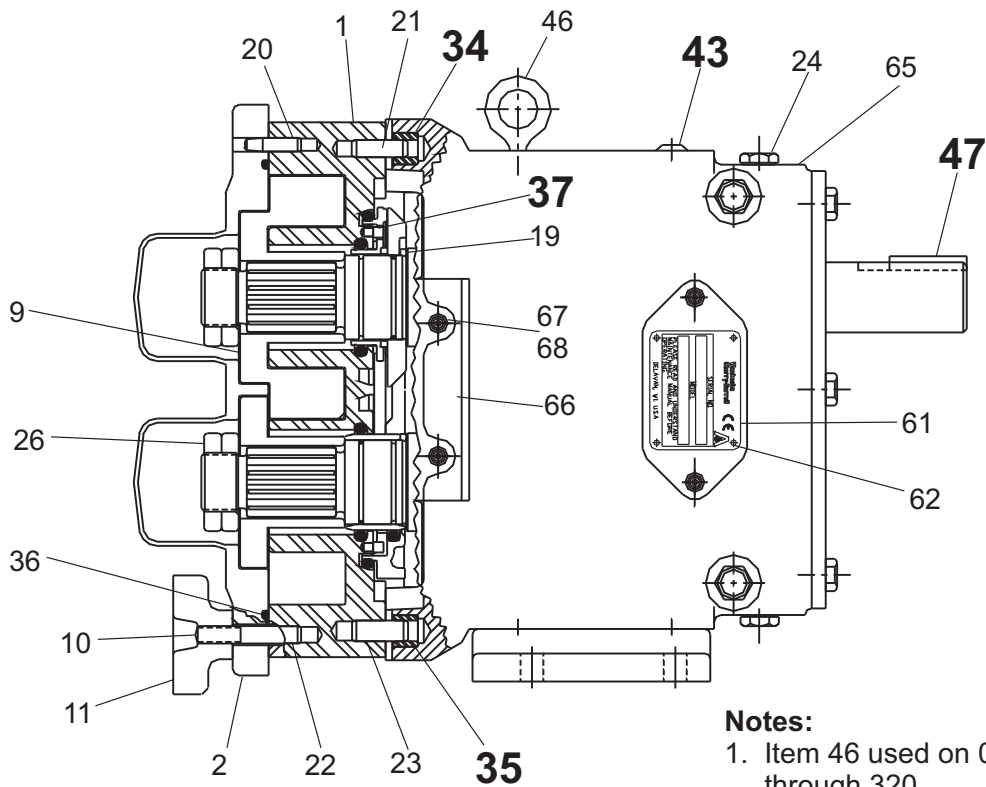

PD100-315

030-033A-034-040-UI Common Parts, cont'd

ITEM NO.	DESCRIPTION	QTY. PER PUMP	PART NO.	NOTES
33A	5/16-18 x .75" HHCS, Std gear case	6	30-283	
	1/2-20 x .50" HHCS, SS Gear case	6	30-526	
33B	5/16-18 x .75" SHCS, Brg Ret. Std gear case	8	30-296	
	5/16-18 x .75" SHCS, Brg Ret., SS Gear case	8	30-29	
33C	5/16" Flat Washer, Std gear case	6	43-194	
34	Dowel Bushing, Upper	1	BD0 116 000	
35	Dowel Bushing, Lower	1	BD0 116 100	
* 36	030-034-040-U1 O-Ring, Pump Cover, Buna N	1	N70261	
	030-034-040-U1 O-Ring, Pump Cover, EPDM	1	E70261	
	030-034-040-U1 O-Ring, Pump Cover, FKM	1	V70261	
	030-034-040-U1 O-Ring, Pump Cover, Silicone	1	S75261	
	033A-U1 O-Ring, Pump Cover, Outer, EPDM	1	033 117 012+	11
	033A-U1 O-Ring, Pump Cover, Outer, FKM	1	033 117 014+	11
	033A-U1 O-Ring, Pump Cover, Outer, Silicone	1	033 117 013+	11
* 36A	033A-U1 O-Ring, Pump Cover, Inner, EPDM	1	033 117 002+	11
	033A-U1 O-Ring, Pump Cover, Inner, FKM	1	033 117 004 +	11
	033A-U1 O-Ring, Pump Cover, Inner, Silicone	1	033 117 003+	11
* 36B	034-U1 O-Ring, Rectangular Flange	1	N70260	14
	034-U1 O-Ring, Rectangular Flange	1	N70357	14
37	Stop Pin, Seal	2	030 126 000+	
39	Lockwasher, Gear	2	CD0 036 W00	
41	Locknut, Gear	2	CD0 036 N00	
42	Gear Case Shim, Cl	1	040 110 000+	
	Gear Case Shim, SS	1	102285+	
	Pump Pedestal, 6.25"	1	BD0 110 SM0	
43	Plastic Cap Plug	8	000 121 002+	
44	3/8-16 x 1" SHCS, Std gear case	4	30-344	
	3/8-16 x 1" SHCS, SS gear case	4	30-189	
45	Body Retaining Screw (030,033,034-U1 only)	2	30-211	
	Body Retaining Screw (040-U1 only)	2	30-543	
46	Eye Bolt	2	30-360	
47	Key, Coupling - 1/4 x 1/4 x 1"	1	000 037 002+	
48	Cleanout Plug	2	41013+	
* 57	033A-U1 O-Ring, Port, Inner	2	S75223	11
* 58	033A-U1 O-Ring, Port, Outer	2	V70232	11
59	033A-U1 2-1/2" 131 "I" Line Clamp	2	0344223+	11
60	033A-U1 Aseptic Ferrule , 2-1/2"	2	BD0 267 230	11

NOTES:

PL5060-CH38a

11. Used on 033A-U1 only.

14. New O-Ring N70357 introduced in 2001. Fits close to inlet opening.

* Recommended Spare Parts

030-033A-034-040-UI Common Parts, cont'd

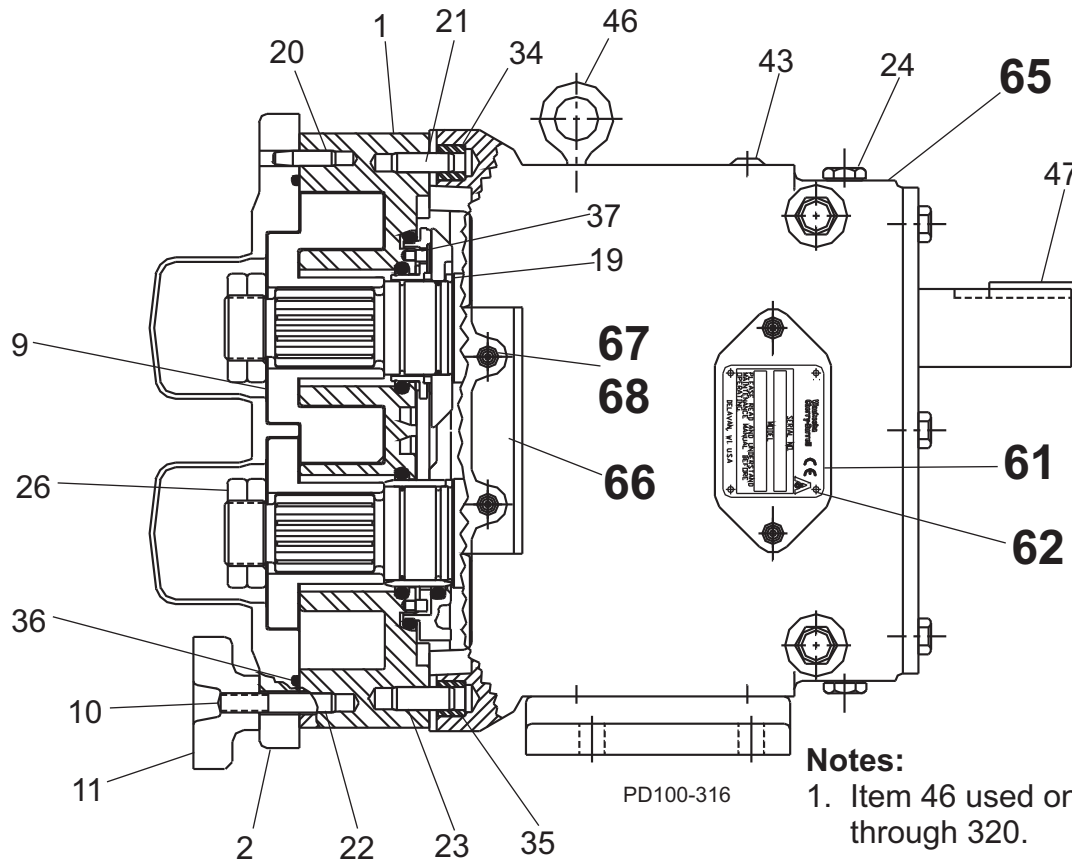

030-033A-034-040-UI Common Parts, cont'd

ITEM NO.	DESCRIPTION	QTY. PER PUMP	PART NO.	NOTES
61	Name Plate, Sanitary	1	001 061 002+	
62	#2 x .125" RHDS	4	30-355	
63	O-ring Removal Tool	1	AD0 096 001	
64	Rotor Nut Wrench, SS	1	109896+	
	030-034-U1 Wrench, Jacketed Cover	1	CD0 019 001	
65	Caution Plate	2	33-62	
66	Warning Label	2	33-63	
67	030-033A-040-U1 Grease Fitting, 1/8"	4	BD0 092 000	
	034-U1 Grease Fitting, 1/8"	4	BD0 092 100	
68	Plastic Cap, Grease Fitting	4	BD0 093 000	

PL5060-CH39a

060-064-130-134-133A-UI Pump Parts

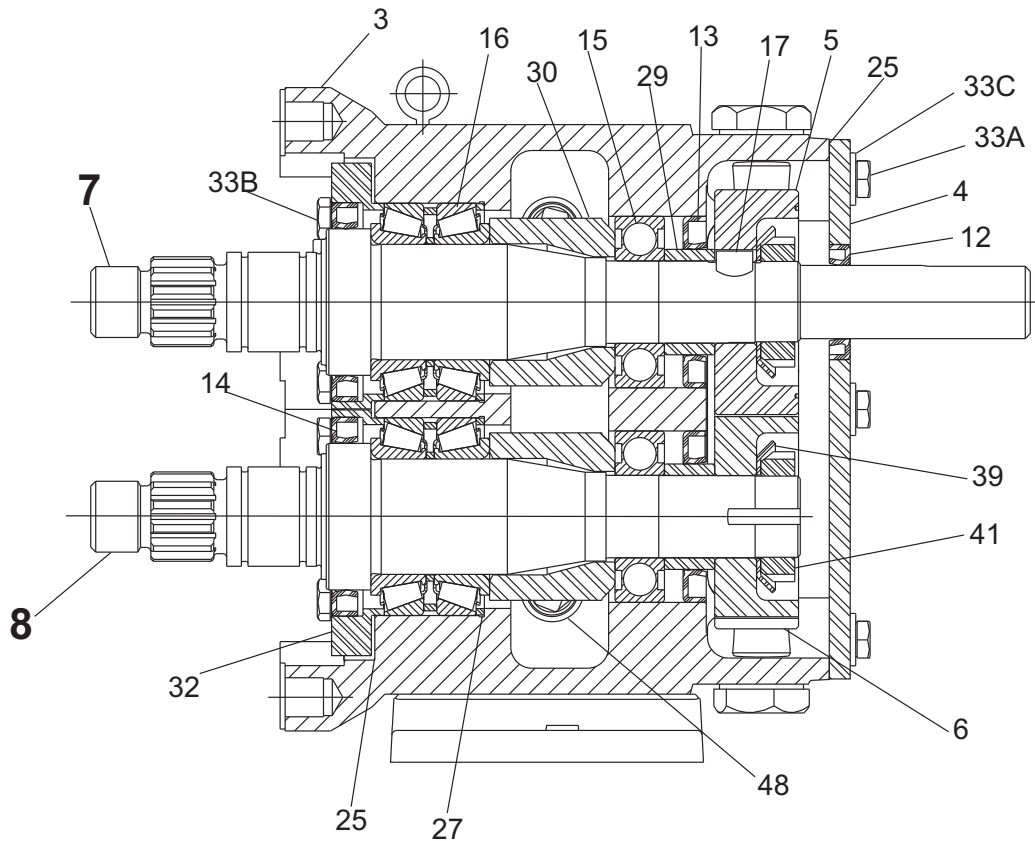
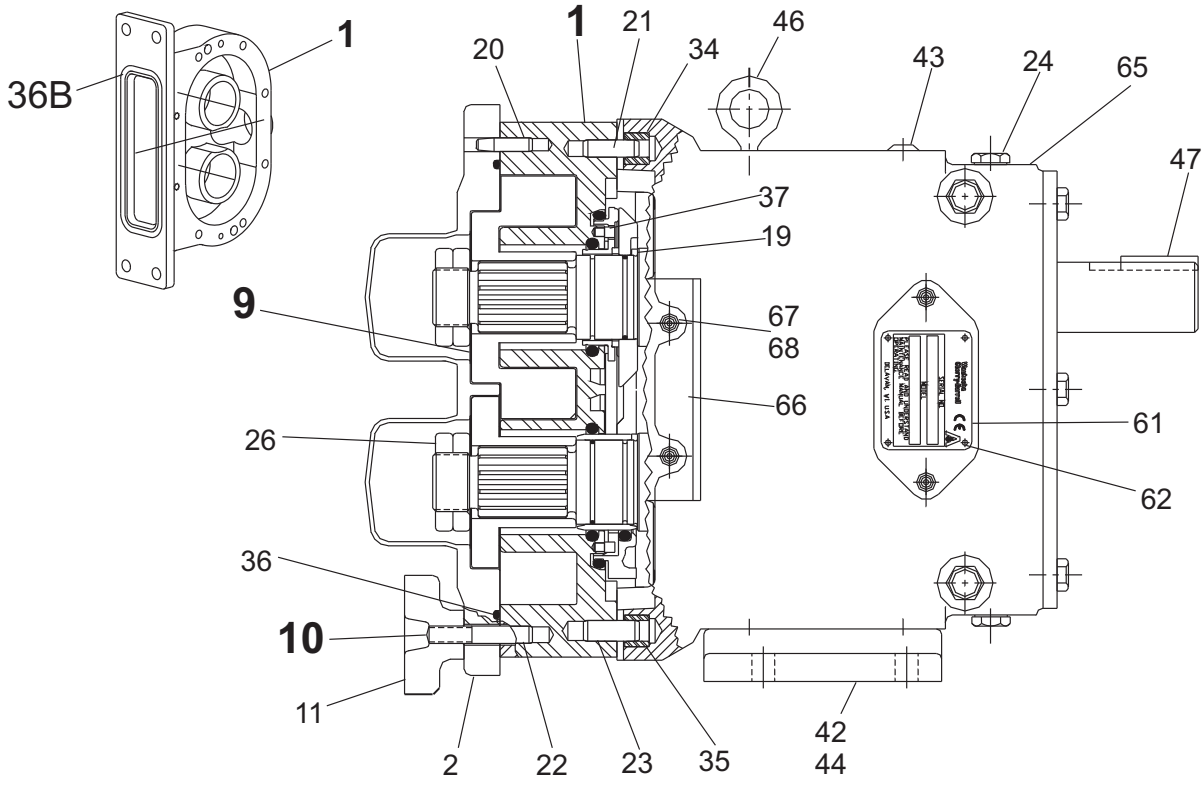

PD100-317

060-064-130-134-133A-UI Pump Parts

ITEM NO.	DESCRIPTION	QTY. PER PUMP	PART NO.	NOTES
1	060-064-130-134-UI Pump Body	1	See Note 1	1
	133A-UI Pump Body with Flush	1	133 001 020+	
7	060-064-UI Drive Shaft	1	060 008 001+	
	060-064-UI Drive Shaft, Optional 17-4PH	1	35145+	
	130-134-UI Drive Shaft	1	130 008 001+	
	130-134-UI Drive Shaft, Optional 17-4PH	1	35394+	
	133A-UI Drive Shaft	1	133 008 001+	
	133A-UI Drive Shaft, Optional 17-4PH	1	34470+	
8	060-064-UI Short Shaft	1	060 009 001+	
	060-064-UI Short Shaft, Optional 17-4PH	1	35146+	
	130-134-UI Short Shaft	1	130 009 001+	
	130-134-UI Short Shaft, Optional 17-4PH	1	35392+	
	133A-UI Short Shaft	1	133 009 001+	
	133A-UI Short Shaft, Optional 17-4PH	1	34471+	
9	060-064-UI Rotor, Twin Wing, Alloy 88	2	060 010 000+	2
	060-064-UI Rotor, Twin Wing, 316SS	2	060 010 200+	2
	060-UI Rotor, Single Wing, Alloy 88	2	117343+	2, 12, 13
	130-134-UI Rotor, Twin Wing, Alloy 88	2	130 010 000+	2
	130-134-UI Rotor, Twin Wing, 316SS	2	130 010 200+	2
	130-UI Rotor, Single Wing, Alloy 88	2	117360+	2, 12A, 13
	133A-UI Rotor, Twin Wing, Alloy 88	2	133 010 020 +	2
	133A-UI Rotor, Single Wing, Alloy 88	2	117377+	2, 12B
10A	060-UI Stud	8	108843+	
10B	060-UI Stud, Jacketed Cover	8	108846+	
10C	060-UI Stud Retainer Assembly	1	070 064 000+	5
10D	064-UI Stud	6	108843+	
	064-UI Stud	2	0C1 050 000	
10E	064-UI Stud, Jacketed Cover	6	108846+	
	064-UI Stud, Jacketed Cover	2	35556+	
10F	130-133A-UI Stud	8	130 011 000+	
10G	130-UI Stud, Jacketed Cover	8	130 011 001+	
10H	130-133A-UI Stud Retainer Assembly	1	140 064 000+	5
10I	134-UI Stud	6	130 011 000+	
	134-UI Stud	2	0C1 050 000	
10J	134-UI Stud, Jacketed Cover	6	130 011 001+	
	134-UI Stud, Jacketed Cover	2	35556+	

NOTES:

PL5060-CH48

1. Contact Factory with Serial Number of pump for Part Number.
2. Standard clearances and finishes for Rotor Part Numbers shown.
Contact Factory for optional clearances and finishes.
5. No longer manufactured, consult factory for upgrade of gear case subassembly.
12. Replaces 060 010 010 straight and 060 010 090 90° (degree) rotors.
- 12A. Replaces 130 010 010 straight and 130 010 090 90° (degree) rotors.
- 12B. Replaces 133 010 010 straight and 133 010 090 90° (degree) rotors.
13. Single wing rotors cannot be used in Rectangular Flange Inlet pumps.

060-064-130-134-133A-UI Common Parts

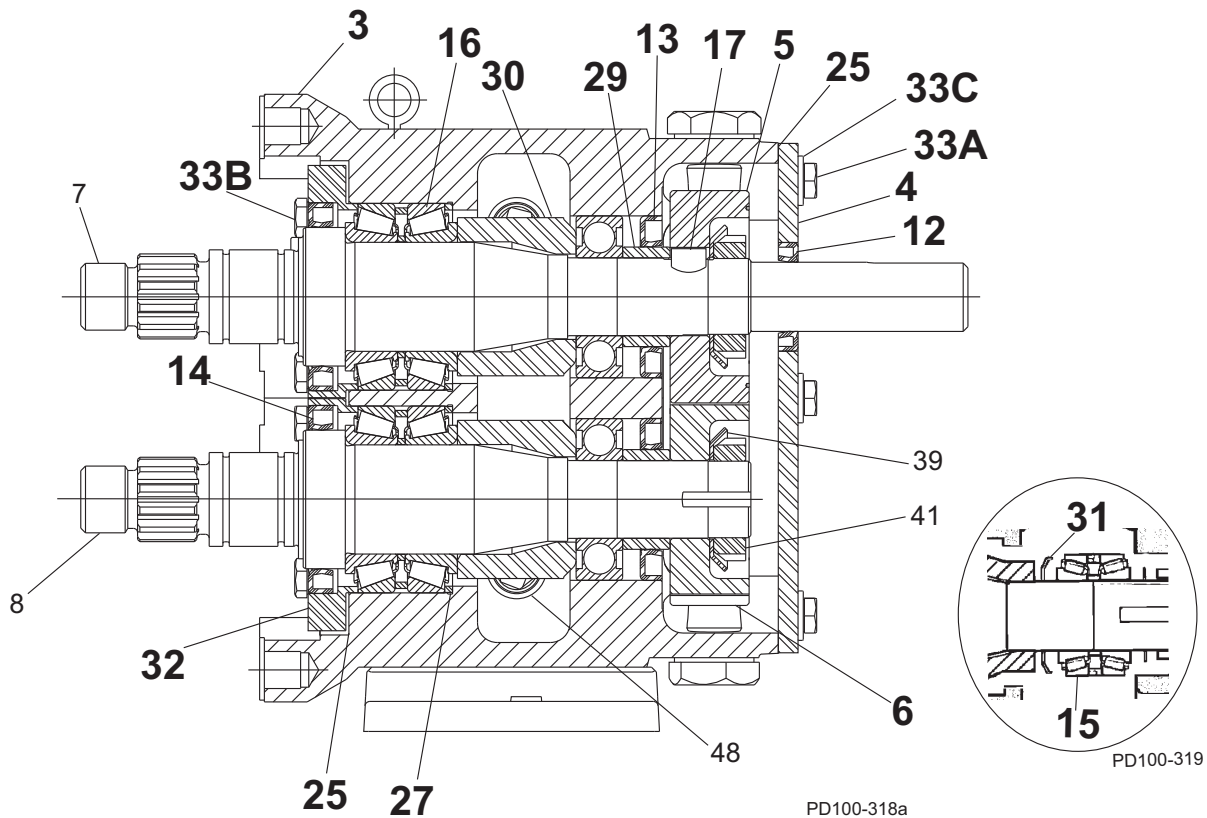
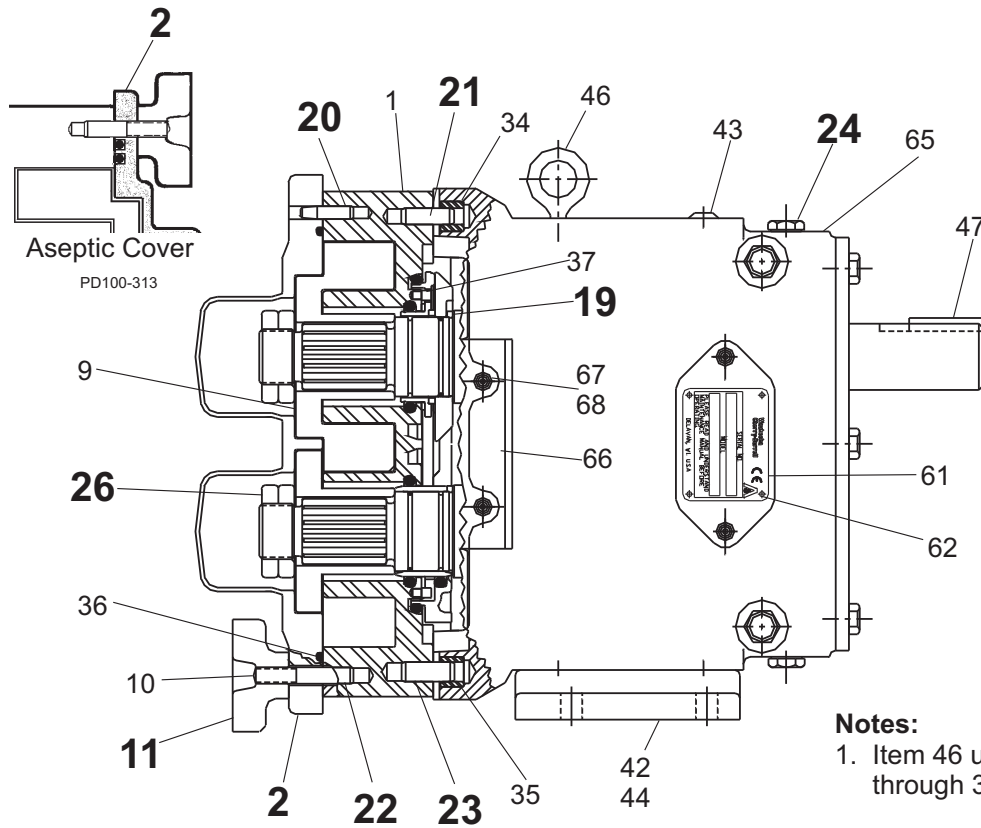

See also "Grease Seal, Bearing Retainer, O-Ring Seal Carrier Part Number Reference" on page 91.

060-064-130-134-133A-UI Common Parts

ITEM NO.	DESCRIPTION	QTY. PER PUMP	PART NO.	NOTES
2	060-064-130-134-U1 Pump Cover	1	CD0 002 S00	
	060-064-130-134-U1 Jacketed Cover	1	CD0 002 J10	
	133A-U1 Pump Cover	1	133 002 020+	
	Pump Cover Vented - Complete Assembly			
	060-064-130-134-U1 Manual (over 150 PSI)	1	CVR00036	
	060-064-130-134-U1 Manual (under 150 PSI)	1	CVR00024	
	060-064-130-134-U1 Pneumatic	1	CVR00053	
	060-064-130-134-U1 Piston	1	CVR00054	
3	060-U1 Gear Case Assembly, CI	1	060 108 000-C	6
	060-U1 Gear Case Assembly, SS	1	060 108 004-C	6
	064-U1 Gear Case Assembly, CI	1	064 108 000-C	6
	064-U1 Gear Case Assembly, SS	1	064 108 004-C	6
	130-U1 Gear Case Assembly, CI	1	130 108 000-C	6
	130-U1 Gear Case Assembly, SS	1	130 108 004-C	6
	133A-U1 Gear Case Assembly, CI	1	133 108 000-C	6
	133A-U1 Gear Case Assembly, SS	1	133 108 004-C	6
	134-U1 Gear Case Assembly, CI	1	134 108 000-C	6
	134-U1 Gear Case Assembly, SS		134 108 004-C	6
4	Gear Case Cover, Steel	1	070 106 000+	
	Gear Case Cover, SS; Optional	1	102282+	
5	Gear, Drive Shaft, Spur	1	107404+	
6	Gear, Short Shaft, Spur	1	107404+	
11	Wing Nut	8	105852+	
	Hex Nut, Optional	8	108371+	
12	Oil Seal, Gear Case Cover	1	000 030 012+	
13	Oil Seal, Gear Case Rear	2	000 030 011+	
14	Grease Seal, Bearing Retainer	2	000 030 009+	
	Bearing Isolator Kit, Incl. STD Bearing Retainer	1	X06614-1	
	Bearing Isolator Kit, Incl. SS Bearing Retainer	1	X06614-2	
15	Bearing, Rear	2	107186+	
16	Bearing, Front	2	060 036 000+	
17	Key, Gear	2	060 037 000+	
19	Drive Pin, Seal Seat and Sleeve	2	CD0 126 000	
20	Dowel Pin, Upper Cover Side	1	CD0 040 000	
21	Dowel Pin, Upper Gear Case Side	1	CD0 040 R00	
22	Dowel Pin, Lower Cover Side	1	CD0 040 100	
23	Dowel Pin, Lower Gear Case Side	1	CD0 040 R10	
24	Oil Plug, M20 x 1.5"	5	115798+	41
	Oil Level Indicator, M20 x 1.5	1	115799+	41
	Plug w/ washer, 3/4-16	6	000 046 004+	40
25	Silicone Sealant	1	000 142 301+	
26	Jam Nut, Rotor	4	060 052 001+	
27	Shim Kit	2	117891+	
29	Spacer, Gear to Rear Bearing	2	107187+	
30	Bearing Spacer	2	060 055 003+	
31	Grease Retainer, Rear Bearing	2	STD 091 002	
32	Bearing Retainer, Front	2	123531+	
	Bearing Retainer, SS	2	101812+	

NOTES:

PL5060-CH49

6. Gear case assembly includes timing gears and 316SS shafts.

40. For pumps shipped prior to 5/15/03.

41. For pumps shipped after 5/15/03.

060-064-130-134-133A-UI Common Parts, cont'd

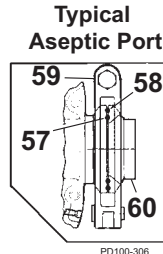
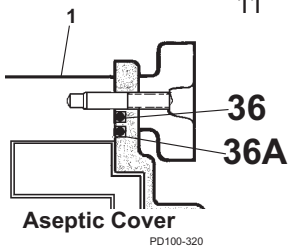
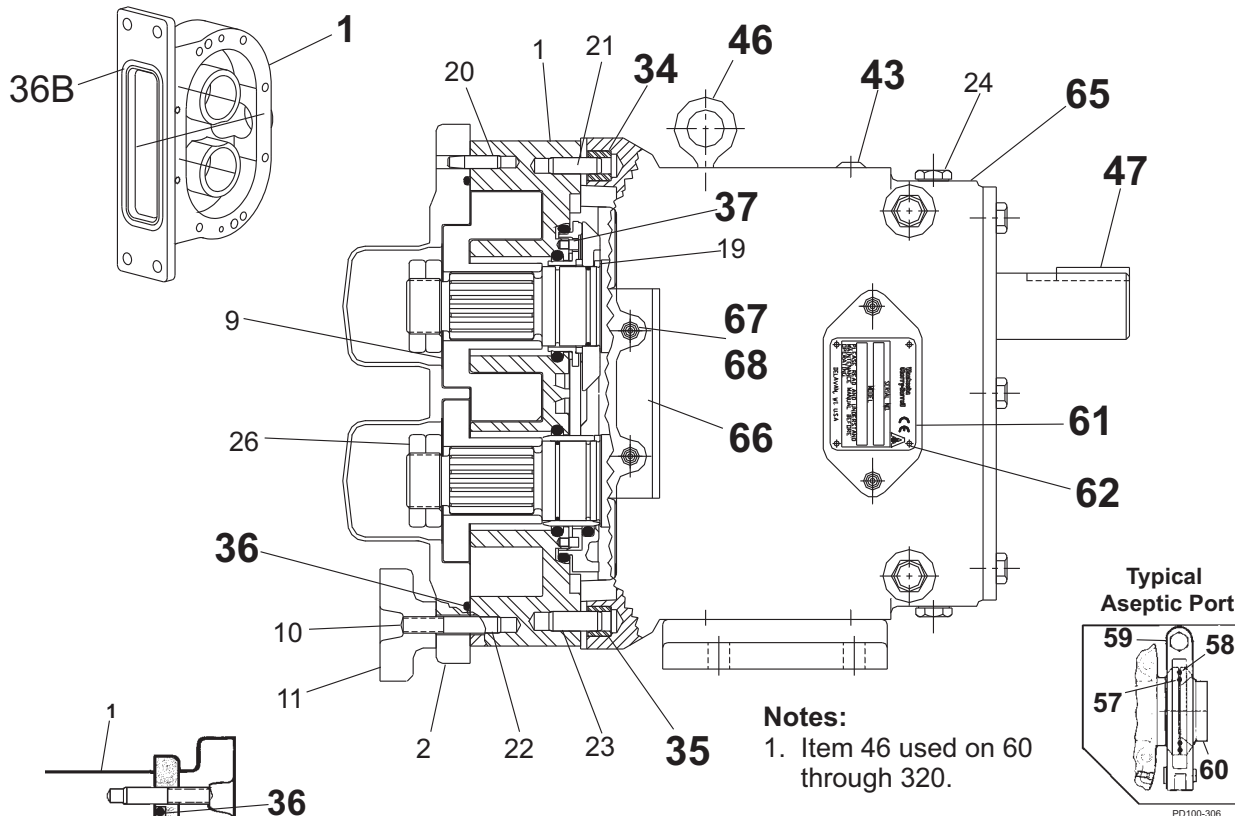

Notes:
1. Item 46 used on 60 through 320.

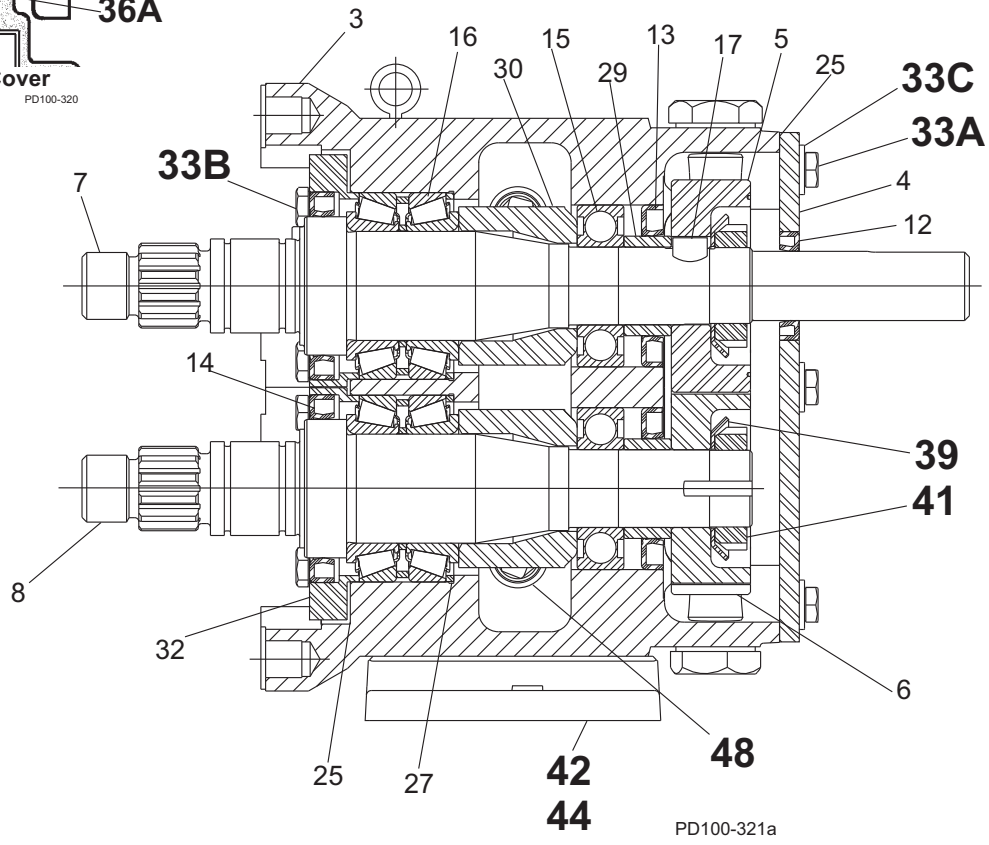

060-064-130-134-133A-UI Common Parts, cont'd

ITEM NO.	DESCRIPTION	QTY. PER PUMP	PART NO.	NOTES
33A	3/8-16 x .75" HHCS, STD Gear Case Cover	6	30-314	
	3/8-16 x .75" HHCS, SS Gear Case	6	30-50	
33B	3/8-16 x 1.25" HHCS, Brg. Ret., Std. Gear Case	8	30-351	
	3/8-16 x 1.25" HHCS, Brg. Ret. SS Gear Case	8	30-60	
33C	3/8" Flat Washer	6	43-189	
34	Dowel Bushing, Upper	1	CD0 116 000	
35	Dowel Bushing, Lower	1	CD0 116 100	
* 36	O-Ring, Pump Cover, Buna N	1	N70272	
	O-Ring, Pump Cover, EPDM	1	E70272	
	O-Ring, Pump Cover, FKM	1	V70272	
	O-Ring, Pump Cover, Silicone	1	S75272	
* 36A	133A-U1 O-Ring, Pump Cover, Inner, EPDM	1	133 117 002+	11
	133A-U1 O-Ring, Pump Cover, Inner, FKM	1	133 117 004+	11
	133A-U1 O-Ring, Pump Cover, Inner, Silicone	1	133 117 003+	11
* 36B	064-U1 O-Ring, Rectangular Flange, Buna N	1	35360+	14
	064-U1 O-Ring, Rectangular Flange, Buna N	1	N70366	14
	134-U1 O-Ring, Rectangular Flange, Buna N	1	N70272	14
	134-U1 O-Ring, Rectangular Flange, Buna N	1	N70369	14
37	Stop Pin, Seal	2	223 126 000+	
39	Lockwasher, Gear	2	STD 136 009	
41	Locknut, Gear	2	STD 236 009	
42	Gear Case Shim, CI	1	070 110 000+	
	Gear Case Shim, SS; Optional	1	102286+	
	Pump Pedestal, 5.5", Optional	1	CD0 110 SM5	
	Pump Pedestal, 10", Optional	1	CD0 110 SM1	
43	Plastic Cap Plug	6	000 121 001+	
44	5/16-18 x 1" SHCS	4	30-275	
45	060-064-U1 Body Retaining Screw	2	30-319	
	130-133A-134-U1 Body Retaining Screw	2	30-423	
46	Eye Bolt	2	30-360	
47	Key, Coupling - 3/8 x 3/8 x 1-5/8"	1	000 037 003+	
48	Cleanout Plug	2	41013+	
* 57	133A-U1 O-Ring, Port, Inner, Silicone	2	S75041	11
	133A-U1 O-Ring, Port, Inner, EPDM	2	E70041	11
* 58	133A-U1 O-Ring, Port, Outer, Silicone	2	S75043	11
	133A-U1 O-Ring, Port, Outer, EPDM	2	E70043	11
* 59	133A-U1 3" 13l "I" Line Clamp	2	0345223+	11
* 60	133A-U1 Aseptic Ferrule, 3"	2	133 267 000+	11
61	Name Plate, Sanitary	1	001 061 002+	
62	#2 x .125" RHDS	4	30-355	
63	O-Ring Removal Tool	1	AD0 096 001	
64	Rotor Nut Wrench, SS	1	109897+	
	060-064-130-134-U1 Wrench, Jacketed Cover	1	060 019 001+	
65	Caution Plate	2	121694+	
66	Warning Label	2	33-60	
67	060, 130, 133A-U1 Grease Fitting, 1/8" (straight)	4	BDO 092 000	
	064-134-U1 Grease Fitting, 1/8" (angled)	4	BDO 092 100	
68	Plastic Cap, Grease Fitting	4	BDO 093 000	

NOTES: * Recommended Spare Parts

PL5060-CH50

11. Used on 133A-U1 only.

14. New O-Rings N70366 (064) and N70369 (134) introduced in 2001. Fits close to inlet opening.

220-223A-224-UI Pump Parts

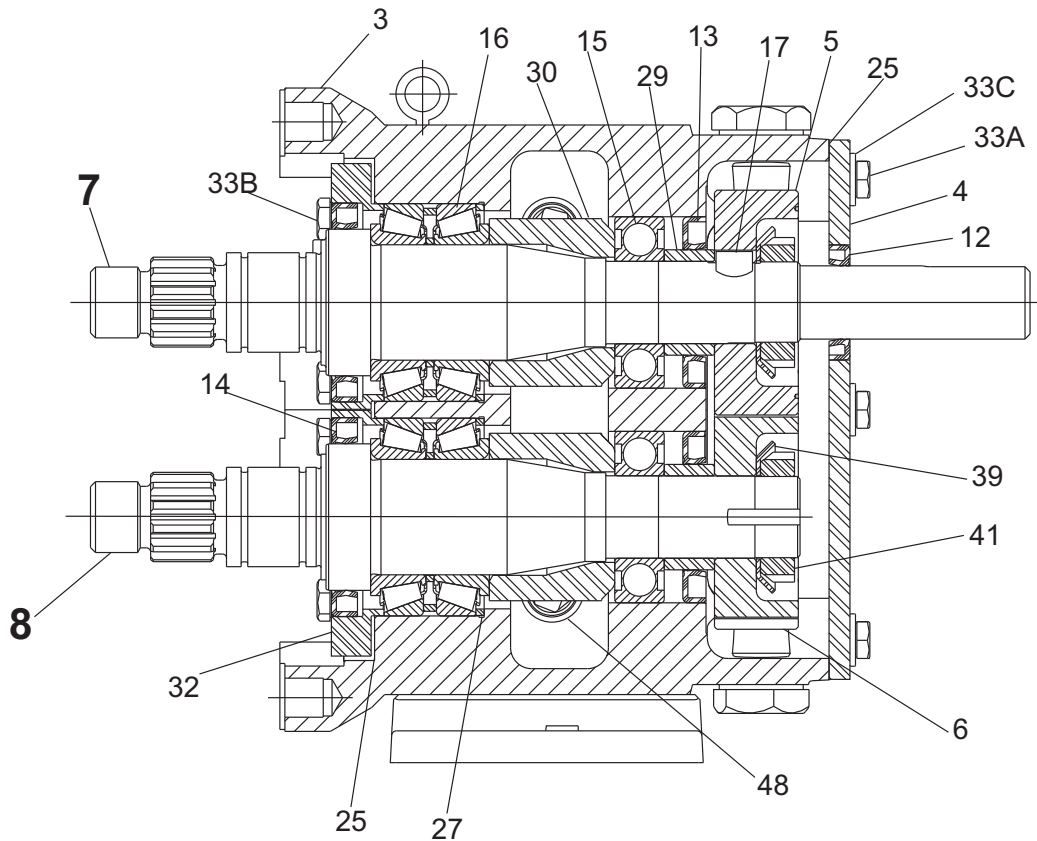
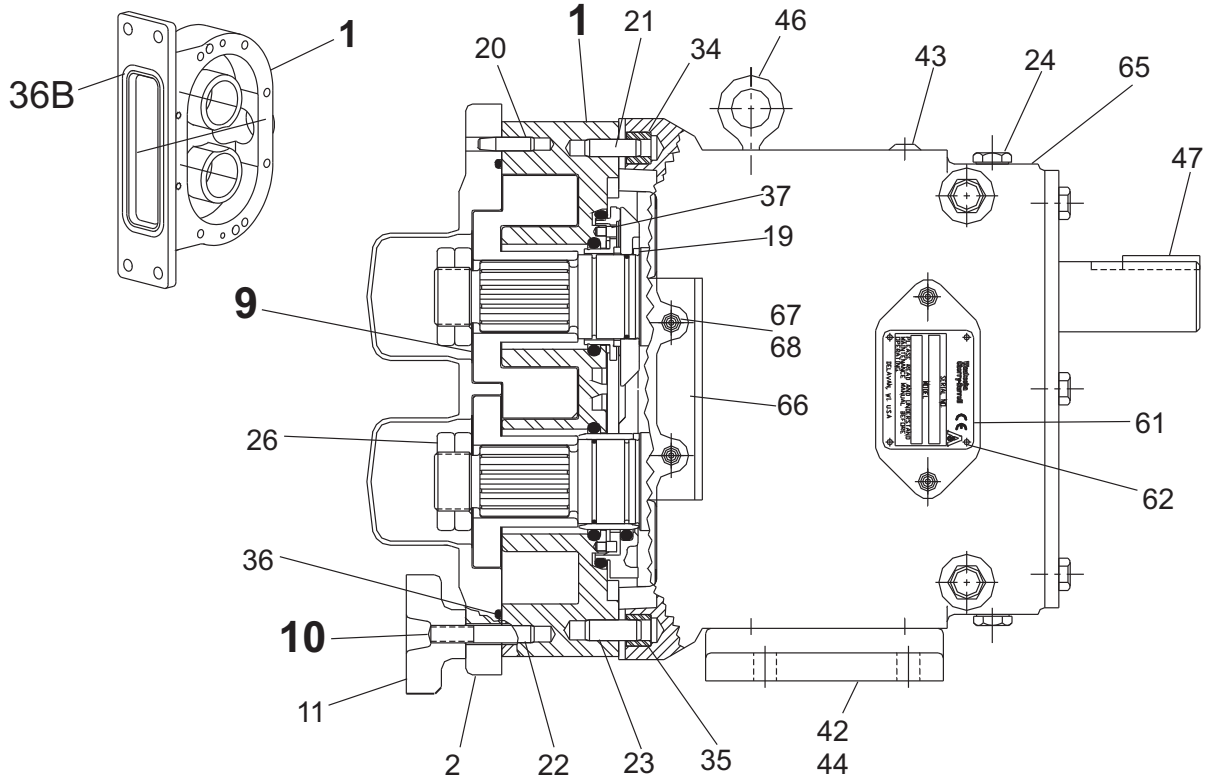

PD100-317

220-223A-224-UI Pump Parts

ITEM NO.	DESCRIPTION	QTY. PER PUMP	PART NO.	NOTES
1	220-U1 Pump Body	1	See Note 1	1
	220-U1 Pump Body with Flush	1	See Note 1	1
	224-U1 Rectangular Flange Inlet Body	1	See Note 1	1
	224-U1 Rect. Flange Inlet Body with Flus	1	See Note 1	1
	223A-U1 Pump Body	1	223 001 020+	
7	220-224-U1 Drive Shaft, Std.	1	220 008 001+	
	220-224-U1 Drive Shaft, Optional 17-4PH	1	35349+	
	223A-U1 Drive Shaft	1	223 008 001+	
	223A-U1 Drive Shaft, Optional 17-4PH	1	35726+	
8	220-224-U1 Short Shaft, Std.	1	220 009 001+	
	220-224-U1 Short Shaft, Optional 17-4PH	1	35350+	
	223A-U1 Short Shaft	1	223 009 001+	
	223A-U1 Short Shaft, Optional 17-4PH	1	35727+	
9	220-224-U1 Rotor, Twin Wing, Alloy 88	2	220 010 000+	2
	220-224-U1 Rotor, Twin Wing, 316SS	2	220 010 200+	2
	220-224-U1 Rotor, Single Wing, Alloy 88	2	117391+	2, 12, 13
	223A-U1 Rotor, Twin Wing, Alloy 88	2	223 010 020+	2
10A	220-U1 Stud	8	108844+	
10B	220-U1 Stud, Jacketed Cover	8	108847+	
10C	224-U1 Stud	6	108844+	
	224-U1 Stud	2	35550+	
10D	224-U1 Stud, Jacketed Cover	6	108847+	
	224-U1 Stud, Jacketed Cover	2	36144+	
	Stud Retainer Assembly	1	230 064 000+	5

PL5060-CH53

NOTES:

1. Contact Factory with Serial Number of pump for Part Number.
2. Standard clearance and finish Part Number shown. Contact Factory for optional clearances and finishes.
5. No longer manufactured, consult factory for upgrade of gear case subassembly.
12. Replaces 220 010 010 straight and 220 010 090 90° rotors.
13. Single wing rotors **cannot** be used in Rectangular Flange Inlet pumps.

220-223A-224-UI Common Parts

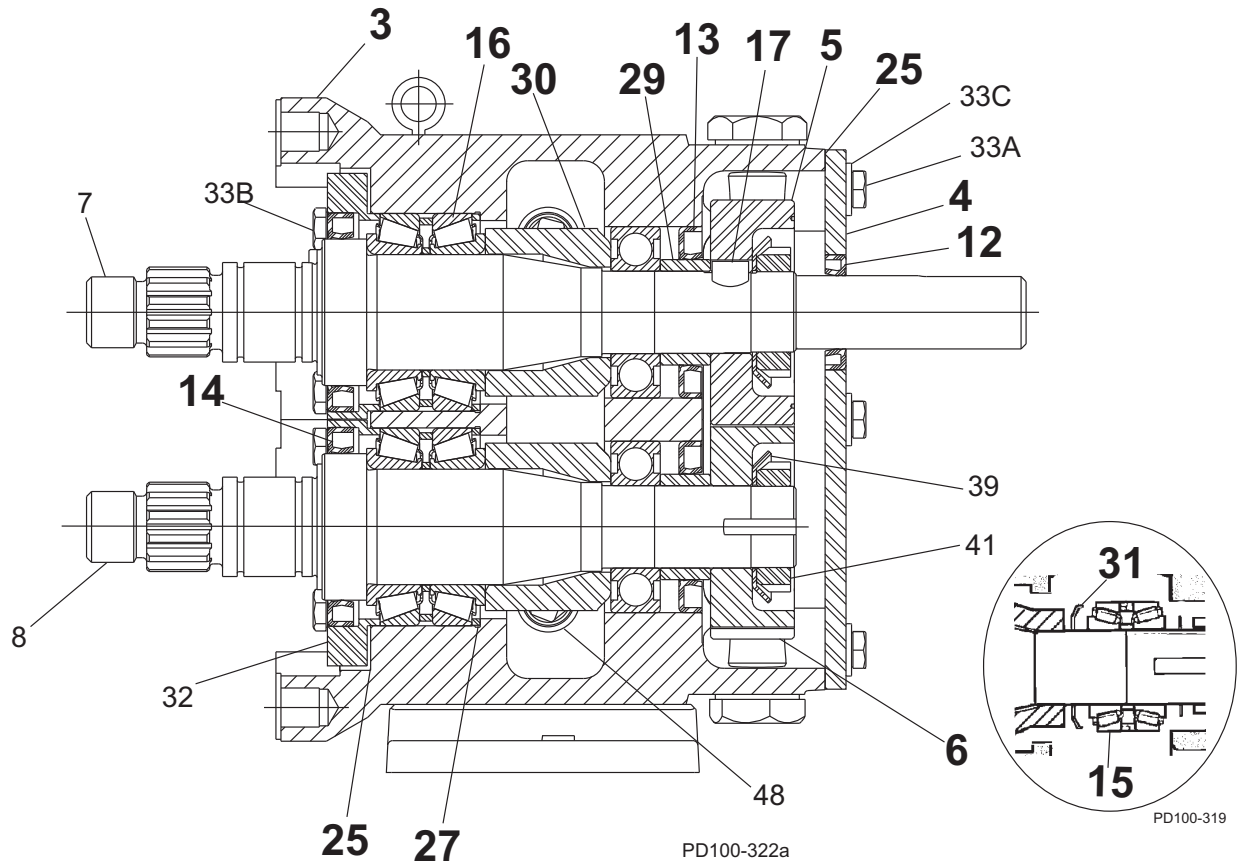
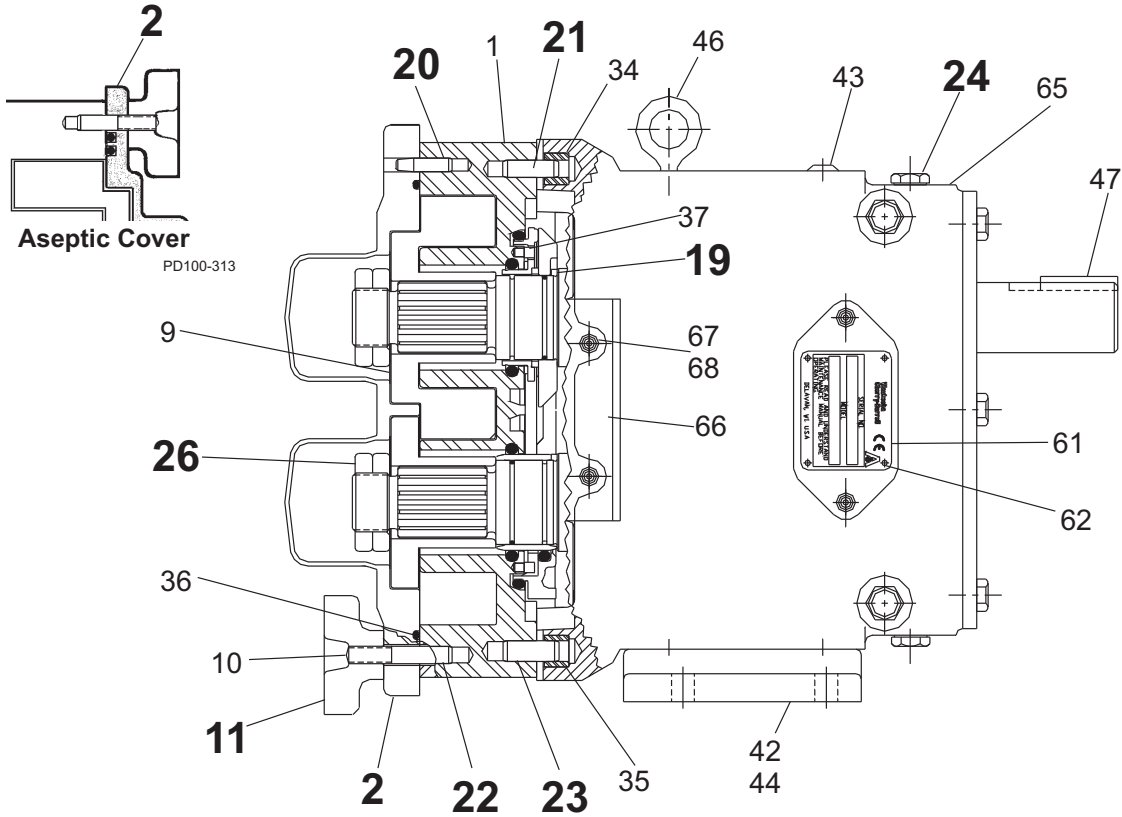

220-223A-224-UI Common Parts

ITEM NO.	DESCRIPTION	QTY. PER PUMP	PART NO.	NOTES
2	220-224-UI Pump Cover	1	GD0 002 S00	
	220-224-UI Jacketed Cover	1	GD0 002 J10	
	223A-UI Pump Cover	1	223 002 020+	
	Pump Cover Vented - Complete Assembly			
	220-224-UI Manual (over 150 PSI)	1	CVR00106	
	220-224-UI Manual (under 150 PSI)	1	CVR00009	
3	220-224-UI Piston	1	CVR00008	
	220-UI Gear Case Assembly, CI	1	220 108 000-C	42
	220-UI Gear Case Assembly, SS; Optional	1	220 108 004-C	42
	223A-UI Gear Case Assembly, CI	1	223 108 000-C	42
	223A-UI Gear Case Assembly, SS; Optional	1	223 108 004-C	42
	224-UI Gear Case Assembly, CI	1	224 108 000-C	42
4	224-UI Gear Case Assembly, SS; Optional	1	224 108 004-C	42
	Gear Case Cover, Steel	1	230 106 000+	
5	Gear Case Cover, SS; Optional	1	102283+	
	Gear, Drive Shaft, Spur	1	110932+	
6	Gear, Short Shaft, Spur	1	110932+	
11	Wing Nut	8	105853+	
	Hex Nut, optional	8	108372+	
12	Oil Seal, Gear Case Cover	1	STD 030 006	
13	Oil Seal, Gear Case Rear	2	STD 119 002	
14	Grease Seal, Bearing Retainer	2	121681+	
	Bearing Isolator Kit, includes Bearing Retainer	1	X06634-2	
15	Bearing, Rear	2	200 035 000+	
16	Bearing, Front	2	200 036 000+	
17	Key, Gear	2	200 037 000+	
19	Drive Pin, Seal Seat and Sleeve	2	CD0 126 000	
20	Dowel Pin, Upper Cover Side	1	GD0 040 000	
21	Dowel Pin, Upper Gear Case Side	1	CD0 040 R00	
22	Dowel Pin, Lower Cover Side	1	GD0 040 100	
23	Dowel Pin, Lower Gear Case Side	1	CD0 040 R10	
24	Plug w/ washer, 3/4-16	6	000 046 004+	40
	Oil Plug, M20 x 1.5"	5	115798+	41
	Oil Level Indicator, M20 x 1.5"	1	115799+	41
25	Silicone Sealant	1	000 142 301+	
26	Jam Nut, Rotor	4	GD0 052 001	
27	Shim Kit	2	117892+	
29	Spacer, Gear to Rear Bearing	2	40878+	
30	Bearing Spacer	2	40752+	
31	Grease Retainer, Rear Bearing	2	STD091001	

NOTES:

PL5060-CH54

40. Pumps shipped prior to 5/15/03
41. Pumps shipped after 5/15/03
42. For pumps shipped prior to 5/15/03: Consult factory and provide serial number for upgrade of gear case assembly.

See also "Grease Seal, Bearing Retainer, O-Ring Seal Carrier Part Number Reference" on page 91.

220-223A-224-UI Common Parts, cont'd

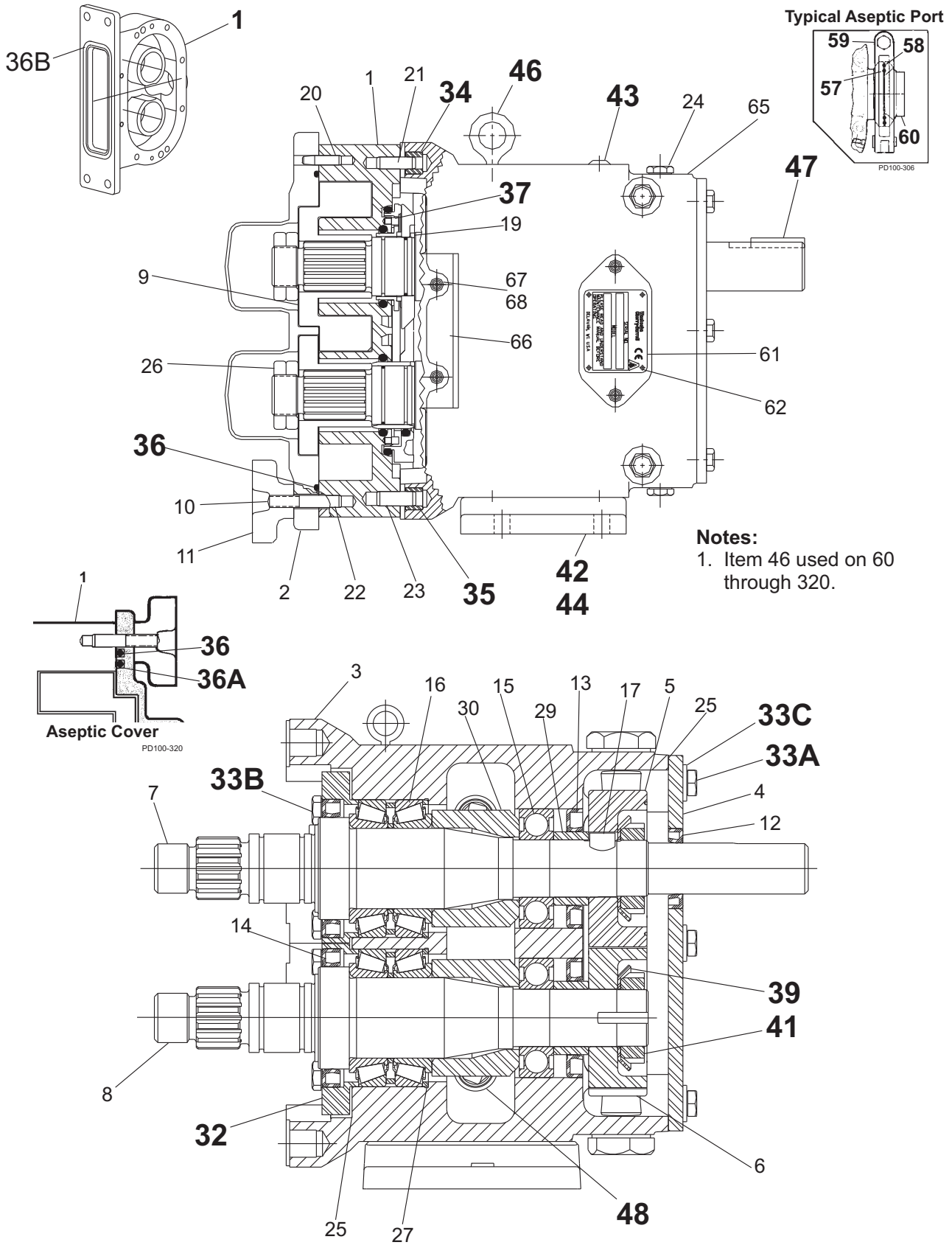

PD100-323a

220-223A-224-UI Common Parts, cont'd

ITEM NO.	DESCRIPTION	QTY. PER PUMP	PART NO.	NOTES
32	Bearing Retainer, Front; STD.	2	220 080 000+	
	Bearing Retainer, Front; SS	2	101813+	
33A	3/8-16 x .75" HHCS, Std gear case	6	30-314	
	3/8-16 x .75" HHCS, SS Gear case	6	30-50	
33B	3/8-16 x 1.25" SHCS, Brg Ret. Std gear case	8	30-351	
	3/8-16 x 1.25" SHCS, Brg Ret., SS Gear case	8	30-60	
33C	3/8" Flat Washer, Std gear case	6	43-189	
34	Dowel Bushing, Upper	1	CD0 116 000	
35	Dowel Bushing, Lower	1	CD0 116 100	
* 36	O-Ring, Pump Cover, Buna N	1	GD0 117 000	
	O-Ring, Pump Cover, EPDM	1	GD0 117 002	
	O-Ring, Pump Cover, FKM	1	GD0 117 V00	
	O-Ring, Pump Cover, Silicone	1	GD0 117 SC0	
* 36A	223A-UI O-Ring, Pump Cover, Inner, EPDM	1	223 117 002+	11
	223A-UI O-Ring, Pump Cover, Inner, FKM	1	V70278	11
	223A-UI O-Ring, Pump Cover, Inner, Silicone	1	223 117 003+	11
36B	224-UI O-Ring, Rectangular Flange	1	GD0 117 000	12
	224-UI O-Ring, Rectangular Flange	1	N70376	12
37	Stop Pin, Seal	2	223 126 000+	
39	Lockwasher, Gear	2	STD 136 011	
41	Locknut, Gear	2	STD 236 011	
42	Gear Case Shim, Cl	1	230 110 000+	
	Gear Case Shim, SS	1	102287+	
	Pump Pedestal, 9"	1	GD0 110 SM9	
	Pump Pedestal, 13"	1	GD0 110 SM1	
43	Plastic Cap Plug	8	000 121 001+	
44	1/2-13 x 2" SHCS, Std gear case	4	30-111	
	1/2-13 x 2" SHCS, SS gear case	4	30-44	
45	Body Retaining Screw	2	30-499	
46	1/2-13 Eye Bolt	2	30-360	
47	Key, Coupling - 1/2 x 1/2 x 1"	1	000 037 004+	
48	Cleanout Plug	2	41013+	
* 57	223A-UI O-Ring, Port, Inner	2	E70154	11
* 58	223A-UI O-Ring, Port, Outer	2	E70158	11
* 59	223A-UI 4" 13MHHMV "S" Clamp	2	119-87	
* 60	223A-UI Aseptic Ferrule, 4"	2	GGA 267 000	

PL5060-CH55

NOTES:

11. Used on 223A-UI only.

12. New O-Ring N70376 introduced in 2001. Fits close to inlet opening.

* **Recommended Spare Parts**

See also "Grease Seal, Bearing Retainer, O-Ring Seal Carrier Part Number Reference" on page 91.

220-223A-224-UI Common Parts, cont'd

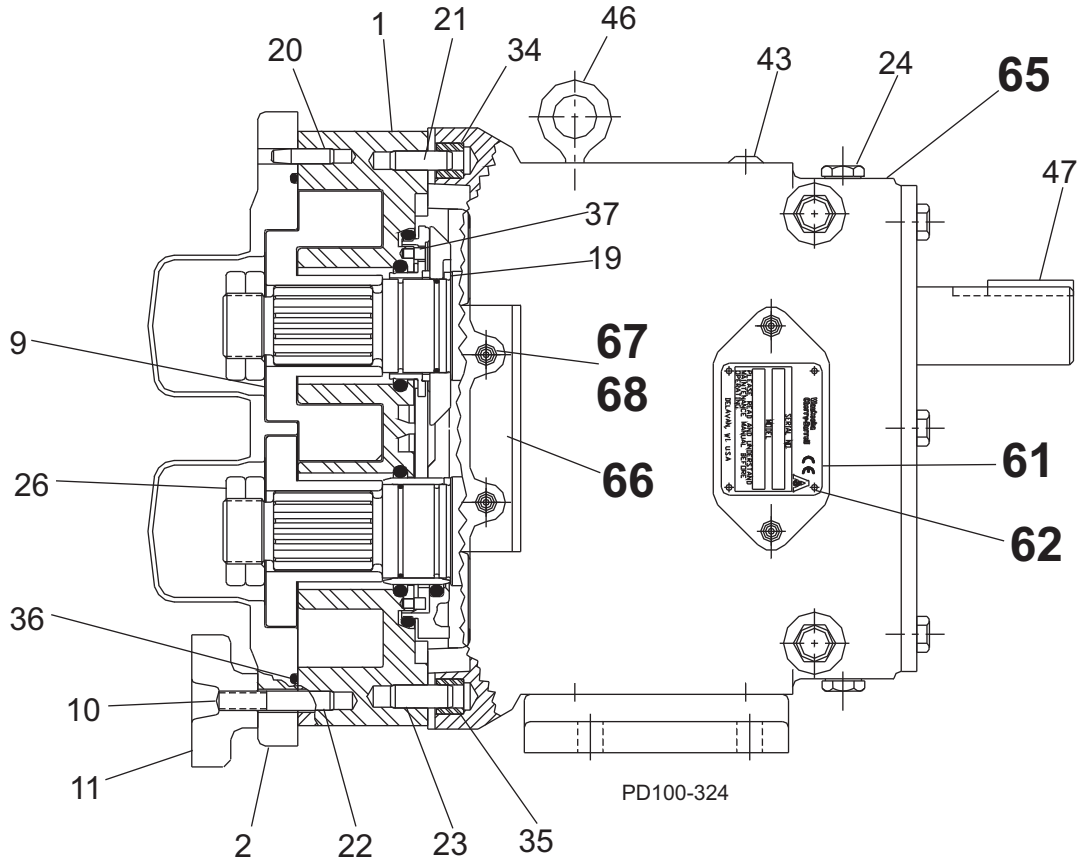

ITEM NO.	DESCRIPTION	QTY. PER PUMP	PART NO.	NOTES
61	Name Plate, Sanitary	1	001 061 002+	
62	#2 x .125" RHDS	4	30-355	
63	O-ring Removal Tool	1	AD0 096 001	
64	Rotor Nut Wrench, SS	1	109898+	
	220-224-U1 Wrench, Jacketed Cover	1	AD0 019 001	
65	Caution Plate	2	33-62	
66	Warning Label	2	33-60	
67	220-223A-U1 Grease Fitting, 1/8"	4	BD0 092 000	
	224-U1 Grease Fitting, 1/8"	4	BD0 092 100	
68	Plastic Cap, Grease Fitting	4	BD0 093 000	

PL5060-CH56

Universal I PD Pump Vented Covers

Manual Vented Cover

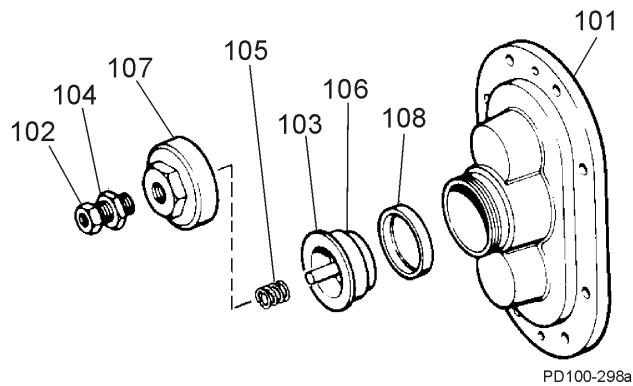

Piston Vented Cover

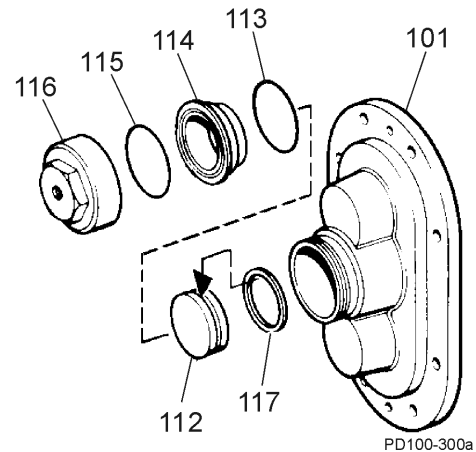

Pneumatic Vented Cover

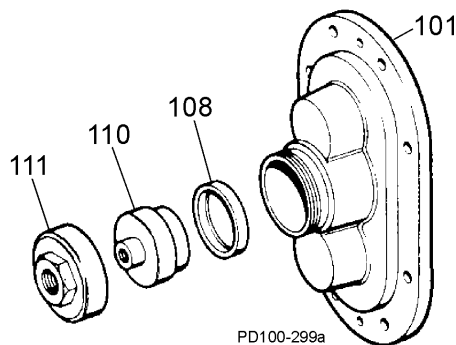

ITEM NO.	DESCRIPTION	QTY. PER PUMP	PART NO.				NOTES
			006-014-015-018-024-UI	030-034-040-UI	060-064-130-134-UI	220-224-UI	
MANUAL VENTED COVER							
101	Vented Cover	1	AD0 002 VS0	BD0 002 VS0	CD0 002 VS0	GD0 002 VS0	
102	Adjusting Screw	1	AD0 072 000		113657+	GD0 072 100	
103	Spring Plunger	1	AD0 073 000		113397+	GD0 073 000	11
104	Locknut	1	AD0 074 000		GD0 074 000		
105	Spring, Medium (less than 150 PSI)	1	AD0 076 000		113523+	113400+	
	Spring, High (more than 150 PSI)	1	ABB 076 100		113400+	113524+	
106	Diaphragm Bushing	1	AD0 077 000		CD0 077 000	GD0 077 000	
107	Cover Nut	1	AD0 075 000		113398+	GD0 075 000	
* 108	Rubber Diaphragm, Buna N	1	AD0 078 000		CD0 078 000	GD0 078 000	
PNEUMATIC VENTED COVER							
101	Vented Cover	1	AD0 002 VS0	BD0 002 VS0	CD0 002 VS0	N/A	
* 108	Diaphragm, Buna N	1	AD0 078 000		CD0 078 000	N/A	
110	Diaphragm Bushing	1	AD0 077 P00		CD0 077 P00	N/A	
111	Cover Nut	1	AD0 075 P00		CD0 075 P00	N/A	
PISTON VENTED COVER							
101	Vented Cover	1	AD0 002 VS0	BD0 002 VS0	CD0 002 VS0	GD0 002 VS0	
112	Piston	1	AD0 073 P10		CD0 073 P10	GD0 073 P10	
* 113	O-Ring, Bushing Seal, Buna N	1	N70223		N70239	N70261	
114	Diaphragm Bushing	1	AD0 077 P10		CD0 077 P10	GD0 077 P10	
* 115	O-Ring, Nut Seal, Buna N	1	N70224		N70240	N70261	
116	Cover Nut	1	AD0 075 P10		CD0 075 P10	GD0 075 P10	
* 117	Piston Seal, Quad Ring	1	AD0 133 000		CD0 133 000	GD0 133 000	9
* 117	Piston Seal, O-Ring	1	N70218		N70236	N70258	9

NOTES: * Recommended Spare Parts

PL5060-CH115

9. Quad Ring and O-Ring can be interchanged.

10. Not used on the 033-UI, 133-UI, or 223-UI pump.

11. For 060-064-130-134, 113397+ is used in pumps manufactured after approx. 03/2000. Pumps manufactured prior to approx. 03/2000 used part # CD0073000.

320-323A-324-UI Pump Parts

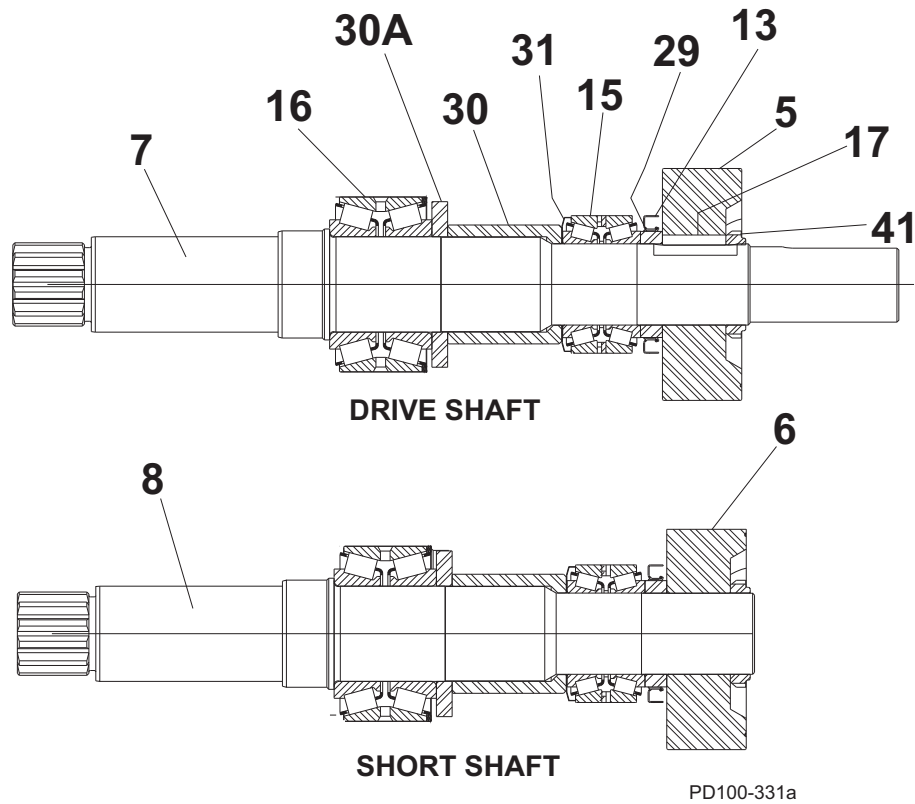
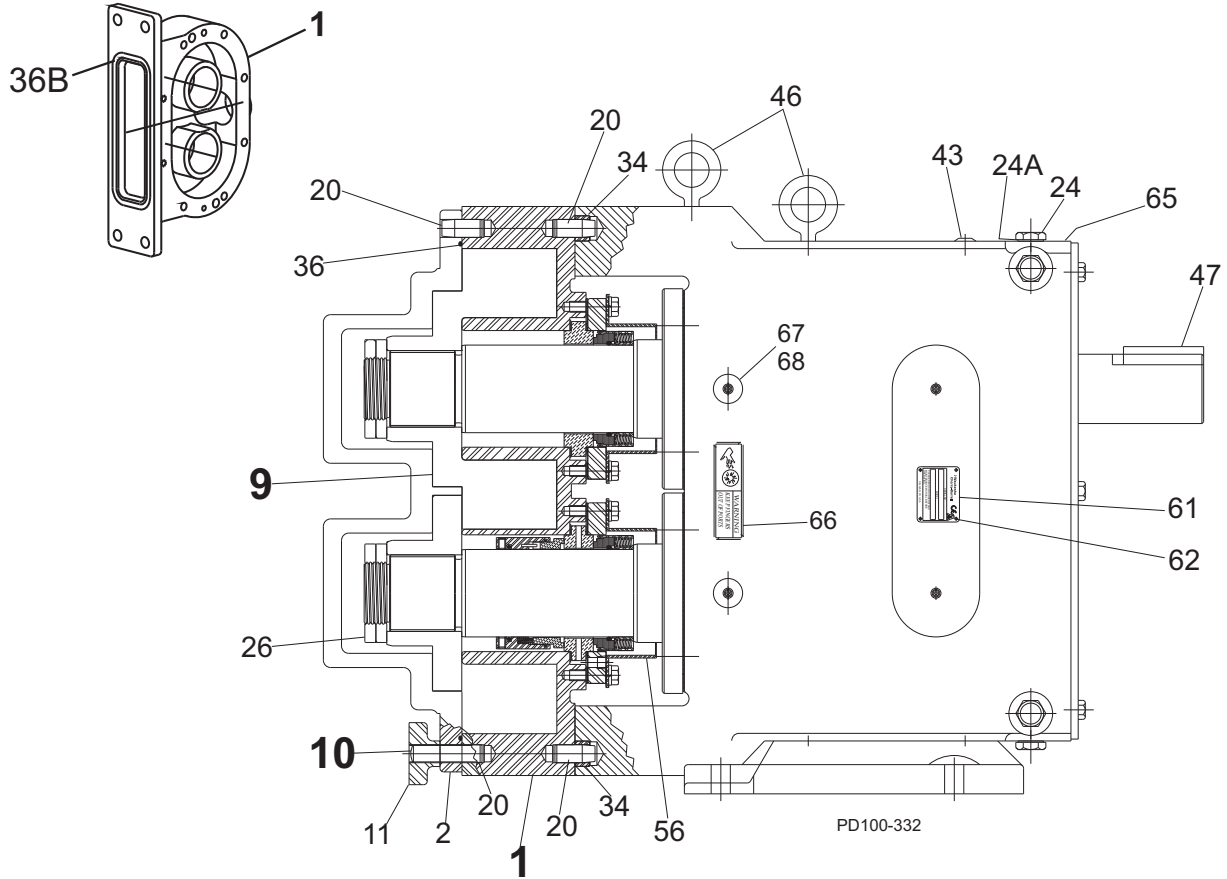

320-323A-324-UI Pump Parts

ITEM NO.	DESCRIPTION	QTY. PER PUMP	PART NO.	NOTES
1	320-324-U1 Pump Body	1	See Note 1	1
	323A-U1 Pump Body	1	323 001 020+	
7	Drive Shaft, Std.	1	113518+	4
	Drive Shaft, Optional 17-4PH	1	113520+	4
	Drive Shaft, Std.		OH1 008 002	3, 5
	Drive Shaft, Optional 17-4PH		33081+	3, 5
	Drive Shaft Kit, Std.	1	113611+	5A
	Drive Shaft Kit, Optional 17-4PH	1	113613+	5A
8	Short Shaft, Std.	1	113519+	4
	Short Shaft, Optional 17-4PH	1	113521+	4
	Short Shaft, Std.		OH1 009 002	3, 5
	Short Shaft, Optional 17-4PH		33204+	3, 5
	Short Shaft Kit, Std.	1	113612+	5A
	Short Shaft Kit, Optional 17-4PH	1	113614+	5A
9	320-324-U1 Rotor, Twin Wing, Alloy 88	2	320 010 000+	2
	320-324-U1 Rotor, Twin Wing, 316SS	2	320 010 200+	2
	323A-U1 Rotor, Twin Wing, Alloy 88	2	323 010 000+	2
10	320-323A-U1 Stud, Cover, Long	4	111291+	4
	324-U1 Stud, Long	4	111291+	
	324-U1 Stud, Short	4	40699+	
10A	Stud, Cover, Short	4	111292+	

NOTES:

1. Contact Factory with Serial Number of pump for Part Number.
2. Standard clearance and finish Part Number shown. Contact Factory for optional clearances and finishes.
3. Pumps shipped prior to July 30, 2001
4. Pumps shipped starting July 30, 2001.
5. No longer manufactured, See shaft kits 113611+ and 113613+, 113612+ and 113614+.
- 5A. Kits replace obsolete shafts OH1 008 002, 33081, OH1 009 002, and 33204 used in obsolete gear case OH1 005 000, which was supplied for pumps shipped prior to July 30, 2001.

Kits 113611+, 113612+, 113613+, and 113614+ Include:

Item no.	Description	Item no.	Description
5,6	Gears P/N 102470+	17	Key, Gear P/N OH1 037 000
7	Drive Shaft P/N 113518+ or 113520+	29	Spacer, Gear P/N 117691+
8	Short Shaft P/N 113519+ or 113521+	30	Spacer Front Bearing P/N 102473+
13	Oil Seal, Case Rear P/N STD 119 000	30A	Bearing Spacer P/N 102472+
15	Bearing, Rear P/N OH1 036 000	31	Grease Retainer P/N STD 091 000
16	Bearing, Front P/N OH1 036 003	41	Locknut, Gear P/N 105697+

PL5060-CH59

320-323A-324-UI Common Parts

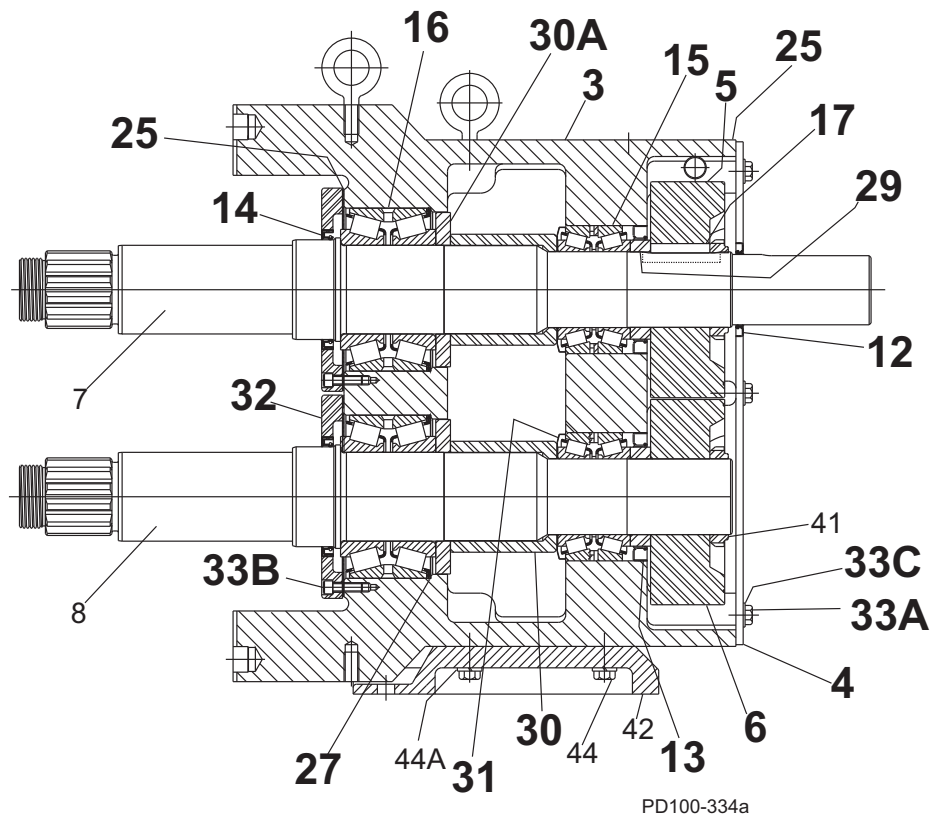
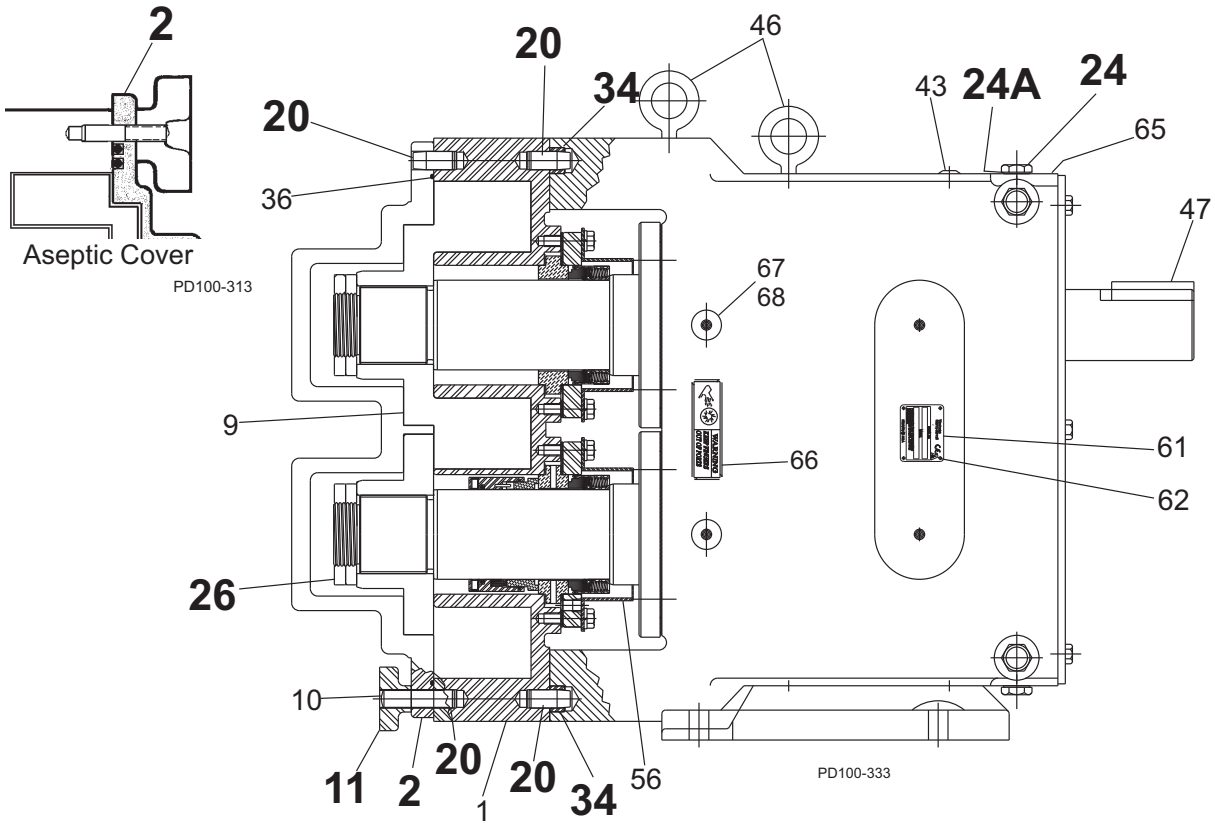

320-323A-324-UI Common Parts

ITEM NO.	DESCRIPTION	QTY. PER PUMP	PART NO.	NOTES
2	320-324-U1 Pump Cover	1	OH1 002 002	
	323A-U1 Pump Cover	1	323 002 020+	
3	320-323-U1 Gear Case Assembly, CI	1	320 108 000-C	5
	324-U1 Gear Case Assembly, CI	1	324 108 000-C	5
4	Gear Case Cover, Steel	1	40669+	
5	Gear, Drive Shaft, Spur	1	102470+	
6	Gear, Short Shaft, Spur	1	102470+	
11	Wing Nut	8	110858+	
	Hex Nut, optional	8	108373+	
12	Oil Seal, Gear Case Cover	1	STD 030 004	
13	Oil Seal, Gear Case Rear	2	102475+	4
	Oil Seal, Gear Case Rear	2	STD 119 000	3
14	Grease Seal, Bearing Retainer	2	121681+	
	Bearing Isolator Kit, includes SS Bearing Retainer	2	X06634-3	
15	Bearing, Rear	2	OH1 036 000	
16	Bearing, Front	2	OH1 036 003	
17	Key, Gear	2	OH1 037 000	
20	Dowel Pins	4	OH1 040 000	
24	Oil Plug, M20 x 1.5"	5	115798+	41
	Oil Level Indicator, M20 x 1.5"	1	115799+	41
	Plug w/ washer, 3/4-16	6	000 046 004+	40
25	Silicone Sealant	1	000 142 301+	
26	Jam Nut, Rotor	4	OH1 052 003	
27	Shim Kit	2	117893+	
29	Spacer, Gear to Rear Bearing	2	102474+	4
	Spacer, Gear to Rear Bearing	2	117691+	3
30	Bearing Spacer	2	102473+	4
30A	Spacer Front Bearing	2	102472+	4
31	Grease Retainer, Rear Bearing	2	STD 091 000	
32	Bearing Retainer, Front	2	OH1 080 000	
33A	3/8-16 x .75" HHCS, Gear Case cover	6	30-314	
33B	5/16-18 x 1" SHCS, Bearing Retainer	8	30-343	
33C	3/8" Washer, Plain	6	43-189	
34	Dowel Bushings	2	OH1 116 000	

NOTES:

PL5060-CH60

3. Pumps shipped prior to July 30, 2001
4. Pumps shipped starting July 30, 2001.
5. For pumps shipped prior to 5/15/03: consult factory and provide serial # for upgrade of gear case subassembly.
40. Pumps shipped prior to 5/15/03
41. Pumps shipped after 5/15/03

See also "Grease Seal, Bearing Retainer, O-Ring Seal Carrier Part Number Reference" on page 91.

320-323A-324-UI Common Parts, cont'd

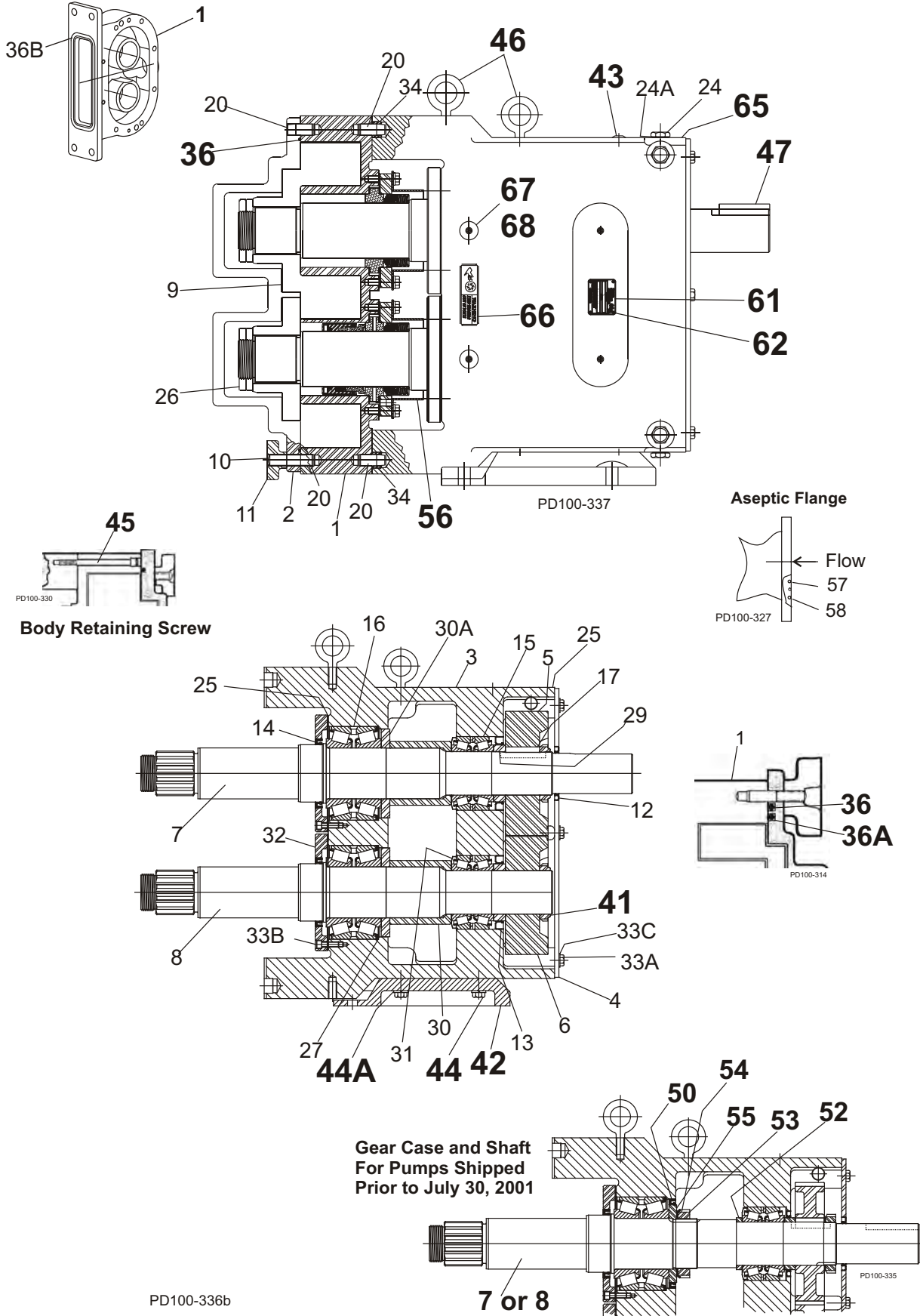

320-323A-324-UI Common Parts, cont'd

ITEM NO.	DESCRIPTION	QTY. PER PUMP	PART NO.	NOTES
* 36	O-Ring, Pump Cover, Buna N	1	N70280	
* 36	O-Ring, Pump Cover, EPDM	1	E70280	
* 36	O-Ring, Pump Cover, FKM	1	V70280	
* 36	O-Ring, Pump Cover, Silicone	1	323 117 013+	
* 36A	323A-U1 O-Ring, Pump Cover, Inner, EPDM	1	323 117 002+	11
* 36A	323A-U1 O-Ring, Pump Cover, Inner, FKM	1	323 117 004+	11
* 36A	323A-U1 O-Ring, Pump Cover, Inner, Silicone	1	323 117 003+	11
36B	324-U1 O-Ring, Rectangular Flange	1	N70382	
41	Locknut, Gear	2	105697+	
42	Gear Case Shim, Cl	1	40288+	
42	Pump Pedestal, 22"	1	324 110 226+	
43	Plastic Cap Plug	6	000 121 001+	
44	1/2-13 x 1.75" SHCS	4	30-250	
44A	Lockwasher, 1/2"	4	43-177	
45	Body Retaining, 3/8-16 x 4" SHCS	2	30-323	
46	1/2-13 Eye Bolt	3	30-360	
47	Key, Coupling - 5/8 x 5/8 x 2"	1	000 037 005+	
48	Cleanout Plug	2	41013+	
56	Guard, Seal	2	113505+	
* 57	O-Ring, Port, Inner, Silicone	2	S75261	11
* 57	O-Ring, Port, Inner, EPDM	2	E70261	11
* 57	O-Ring, Port, Inner, FKM	2	V70261	11
* 58	O-Ring, Port, Outer, Silicone	2	S75265	11
* 58	O-Ring, Port, Outer, EPDM	2	E70265	11
* 58	O-Ring, Port, Outer, FKM	2	V70265	11
61	Name Plate	1	001 061 015+	
62	#2 x .125" RHDS	4	30-355	
63	O-ring Removal Tool	1	AD0 096 001	
64	Rotor Nut Wrench, SS	1	112829+	
65	Caution Plate	2	33-62	
66	Warning Label	2	33-60	
67	320-323A-U1 Grease Fitting, 1/8"	4	BD0 092 000	
67	324-U1 Grease Fitting, 1/8"	4	BD0 092 100	
68	Plastic Cap, Grease Fitting	4	BD0 093 000	

NOTES:

* Recommended Spare Parts

11. Used on 323A-U1 only.

Gear Case and shaft for pumps shipped prior to July 30, 2001

50	Grease Retainer, Gear Case, Front Bearing	2	STD 030 003	3
52	Spacer, Rear Bearing	2	OH1 055 002	3
53	Locknut, Front Bearing	2	OH1 236 001	3
54	Lockwasher, Front Bearing	2	OH1 136 001	3
55	Spacer, Front Bearing	2	OH1 055 001	3

NOTES: 3. Pumps shipped prior to July 30, 2001

PL5060-CH61

PD Pump Seals Model 006-014-015-018-024-030-034-040-UI

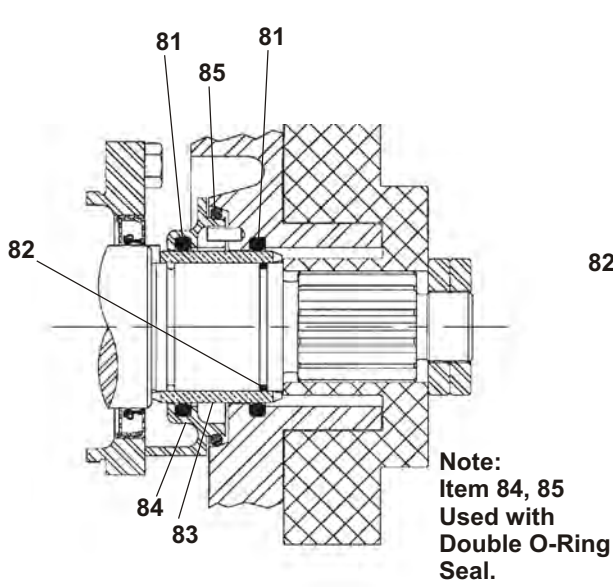

O-Ring Seal

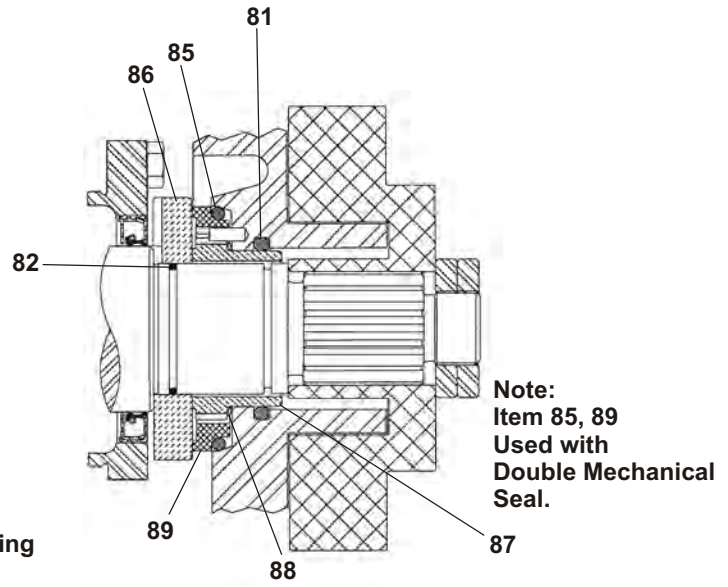

Mechanical Seal

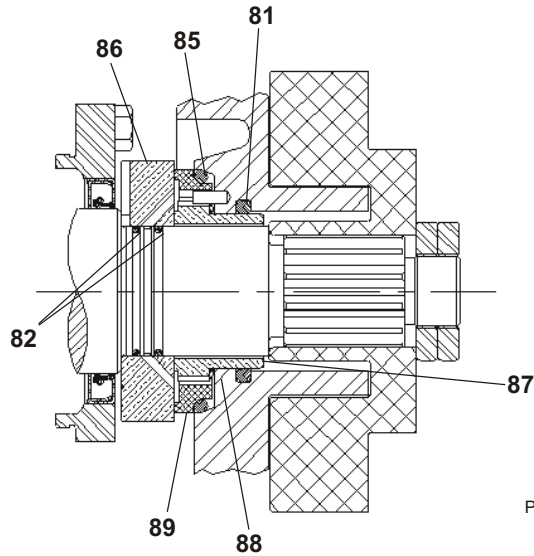

PD100-301-302-304

UI Aseptic Seal
(models 033A-UI, 133A-UI, 223A-UI)

PD Pump Seals Model 006-014-015-018-024-030-034-040-UI

ITEM NO.	DESCRIPTION	QTY. PER PUMP	PART NO. BY MODEL		NOTES
			006-014-015-018-024-UI	030-033A-034-040-UI	
O-RING AND MECHANICAL SEAL PARTS					
* 81	O-Ring, Body, Buna N	2	AD0 079 000	N70327	6
* 81	O-Ring, Body, EPDM	2	AD0 079 002	E70327	6
* 81	O-Ring, Body, FKM	2	AD0 079 V00	V70327	6
* 81	O-Ring, Body, Silicone	2	AD0 079 SC0	S75327	6
* 82	O-Ring, Shaft, Buna N	2	N70022	N70028	
* 82	O-Ring, Shaft, EPDM	2	E70022	E70028	
* 82	O-Ring, Shaft, FKM	2	V70022	V70028	
* 82	O-Ring, Shaft, Silicone	2	S75022	S75028	
* 83	Sleeve, SS	2	015 098 000+	030 098 000+	
* 83	Sleeve, Zirconia	2	015 098 004+	030 098 004+	
* 83	Sleeve, Chrome Oxide	2	015 098 002+	030 098 002+	
84	O-Ring Seal Carrier (after 7/12/04 (NEW))	2	015 034 001+	030 034 001+	7, 10
84	O-Ring Seal Carrier (before 7/12/04 (OLD))	2	015 034 000+	030 034 000+	7, 9
* 85	O-Ring, Outer, Buna N - Seal Carrier	2	N50228	N50335	7, 8
* 85	O-Ring, Outer, EPDM - Seal Carrier	2	n/a	E50335	7, 8
* 85	O-Ring, Outer, FKM - Seal Carrier	2	n/a	V50335	7, 8
* 85	O-Ring, Outer, Silicone - Seal Carrier	2	n/a	S50335	7, 8
* 86	006-014-015-018-024-U1 Seal Seat, Ceramic	2	015 014 002+	n/a	
* 86	006-014-015-018-024-U1 Seal Seat, Chrome Oxide	2	015 014 001+	n/a	
* 86	006-014-015-018-024-U1 Seal Seat, Silicon Carbide	2	015 014 009+	n/a	
* 86	030-034-040-U1 Seal Seat, Ceramic	2	n/a	030 014 002+	
* 86	030-034-040-U1 Seal Seat, Chrome Oxide	2	n/a	030 014 001+	
* 86	030-034-040-U1 Seal Seat, Silicon Carbide	2	n/a	030 014 009+	
* 86	033A-U1 Seal Seat, Ceramic	2	n/a	033 014 002+	11
* 86	033A-U1 Seal Seat, Chrome Oxide	2	n/a	033 014 001+	11
* 86	033A-U1 Seal Seat, Silicon Carbide	2	n/a	033 014 009+	11
* 87	Seal Inner, Carbon (2 piece)	2	015 306 001 +	030 306 001+	
* 87	Seal Inner, Carbon (1 piece)	2	015 306 007+	030 306 007+	
* 87	Seal Inner, Ceramic	2	40635+	40821+	
* 87	Seal Inner, Chrome Oxide	2	015 306 002+	030 306 002+	
* 87	Seal Inner, Silicon Carbide	2	015 306 009+	030 306 009+	
88	Wave Spring	2	015 304 000+	030 304 000+	
* 89	Outer Seal, Carbon (1 piece)	2	015 206 007+	030 206 007+	8
* 89	Outer Seal, Chrome Oxide	2	n/a	030 206 002+	8

NOTES: * Recommended Spare Parts

PL5060-CH34a

- 6. (4) needed per pump with double O-ring Seal.
- 7. Used with double O-Ring Seal.
- 8. Used with double Mechanical Seal.
- 9. Used in pumps manufactured prior to July 2004.
- 10. Used in pumps manufactured since July 2004.
- 11. Used on 033A-U1 only.

See also "Grease Seal, Bearing Retainer, O-Ring Seal Carrier Part Number Reference" on page 91.

PD Pump Seals Model 060-064-130-133A-134-220-223A-224-UI

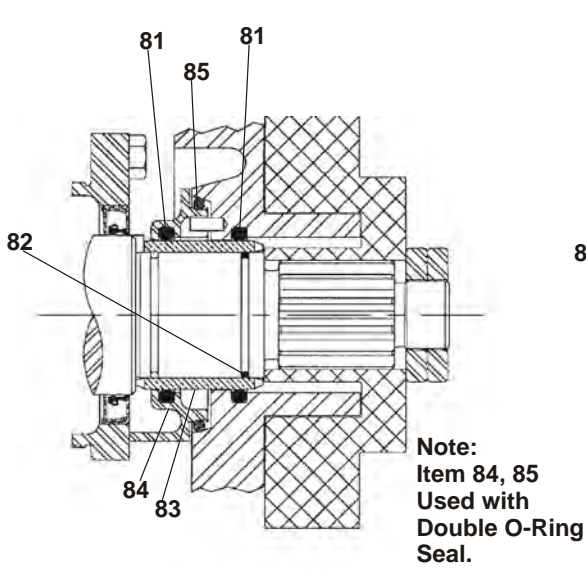

O-Ring Seal

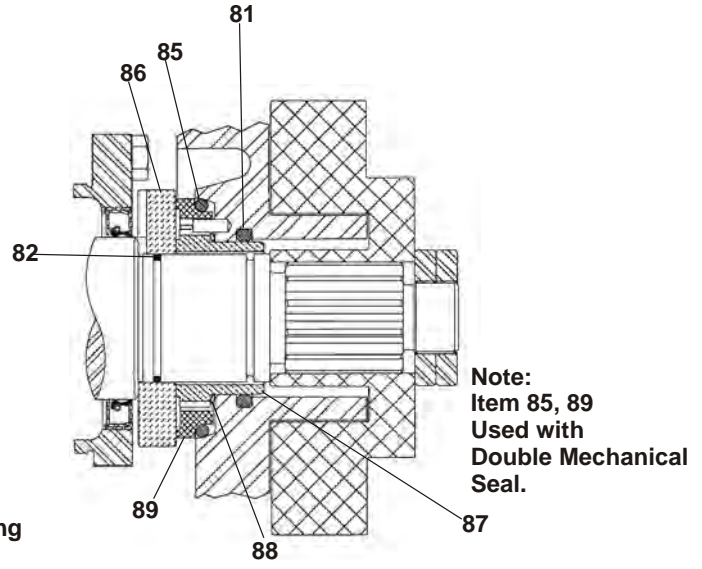

Mechanical Seal

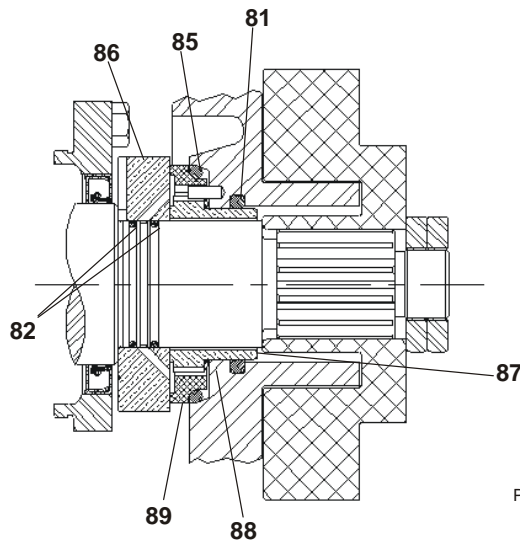

PD100-301-302-304

UI Aseptic Seal
(models 033-UI, 133-UI, 223-UI)

PD Pump Seals Model 060-064-130-133A-134-220-223A-224-UI

ITEM NO.	DESCRIPTION	QTY. PER PUMP	PART NO. BY MODEL		NOTES
			060-064-130-133A-134-U1	220-223A-224-UI	
O-RING AND MECHANICAL SEAL PARTS					
* 81	O-Ring, Body, Buna N	2	N70331	N70338	6
	O-Ring, Body, EPDM	2	E70331	E70338	6
	O-Ring, Body, FKM	2	V70331	V70338	6
	O-Ring, Body, Silicone	2	S75331	S75338	6
* 82	O-Ring, Shaft, Buna N	2	N70131	N70144	16
	O-Ring, Shaft, EPDM	2	E70131	E70144	16
	O-Ring, Shaft, FKM	2	V70131	V70144	16
	O-Ring, Shaft, Silicone	2	S75131	S75144	16
* 83	Sleeve, SS	2	060 098 000+	220 098 000+	
	Sleeve, Zirconia	2	060 098 004+	220 098 004+	
	Sleeve, Chrome Oxide	2	060 098 002+	220 098 002+	
84	O-Ring Seal Carrier (after 7/12/04 (NEW))	2	060 034 001+	220 034 001+	7, 10
	O-Ring Seal Carrier (before 7/12/04 (OLD))	2	060 034 000+	220 034 000+	7, 9
* 85	O-Ring, Outer, Buna N - Seal Carrier	2	N50338	N50344	7, 8
	O-Ring, Outer, EPDM - Seal Carrier	2	E50338	E50344	7, 8
	O-Ring, Outer, FKM - Seal Carrier	2	V50338	V50344	7, 8
	O-Ring, Outer, Silicone - Seal Carrier	2	n/a	S50344	7, 8
* 86	060-064-130-134-U1 Seal Seat, Ceramic	2	060 014 002+	n/a	
	060-064-130-134-U1 Seal Seat, Chrome Oxide	2	060 014 001+	n/a	
	060-064-130-134-U1 Seal Seat, Silicon Carbide	2	060 014 009+	n/a	
	133A-U1 Seal Seat, Ceramic	2	133 014 002+	n/a	11a
	133A-U1 Seal Seat, Chrome Oxide	2	133 014 001 +	n/a	11a
	133A-U1 Seal Seat, Silicon Carbide	2	133 014 009+	n/a	11a
	220-224-U1 Seal Seat, Ceramic	2	n/a	220 014 002+	
	220-224-U1 Seal Seat, Chrome Oxide	2	n/a	220 014 001+	
	220-224-U1 Seal Seat, Silicon Carbide	2	n/a	220 014 009+	
	223A-U1 Seal Seat, Ceramic	2	n/a	223 014 002+	11b
	223A-U1 Seal Seat, Chrome Oxide	2	n/a	223 014 001+	11b
	223A-U1 Seal Seat, Silicon Carbide	2	n/a	223 014 009+	11b
* 87	Seal Inner, Carbon (2 piece)	2	060 306 001+	220 306 001 +	
	Seal Inner, Carbon (1 piece)	2	060 306 007+	220 306 007+	
	Seal Inner, Ceramic	2	40642+	40830+	
	Seal Inner, Chrome Oxide	2	060 306 002+	220 306 002+	
	Seal Inner, Silicon Carbide	2	060 306 009+	220 306 009+	
88	Wave Spring	2	060 304 000+	220 304 000+	
* 89	Outer Seal, Carbon (1 piece)	2	060 206 007+	220 206 007+	8
	Outer Seal, Chrome Oxide	2	060 206 002+	220 206 002+	8

NOTES: * Recommended Spare Parts

PL5060-CH40a

- 6. (4) needed per pump with Double O-ring Seal.
- 7. Used with Double O-Ring Seal.
- 8. Used with Double Mechanical Seal.
- 9. Used in pumps manufactured prior to July 2004.
- 10. Used in pumps manufactured since July 2004.
- 11a. Used on 133A-U1 only.
- 11b. Used on 223A-U1 only.
- 16. (4) needed per pump on 033A-U1 and 133A-U1.

See also "Grease Seal, Bearing Retainer, O-Ring Seal Carrier Part Number Reference" on page 91.

PD Pump Seals Model 320-323A-324-UI

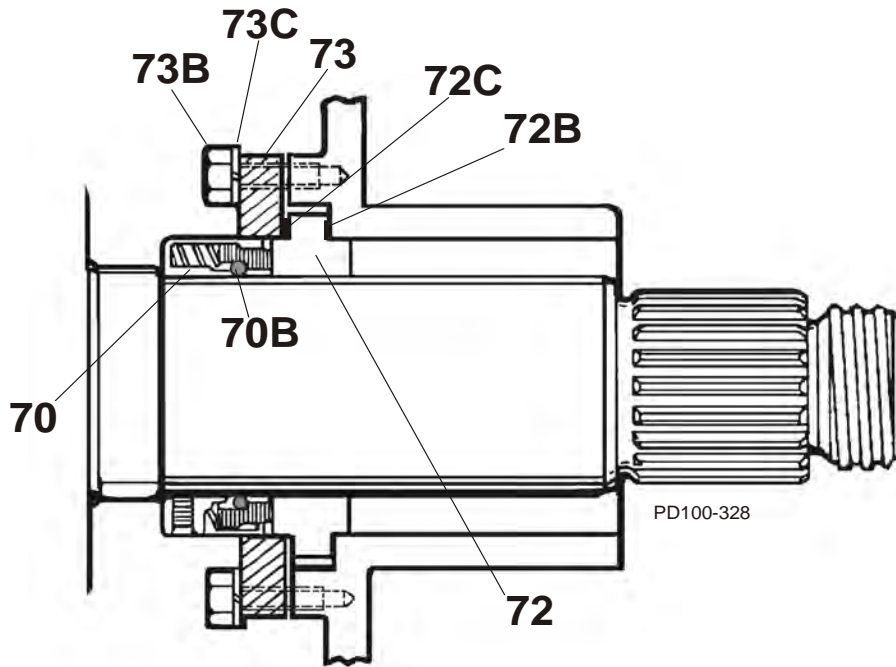

PD100-328-329

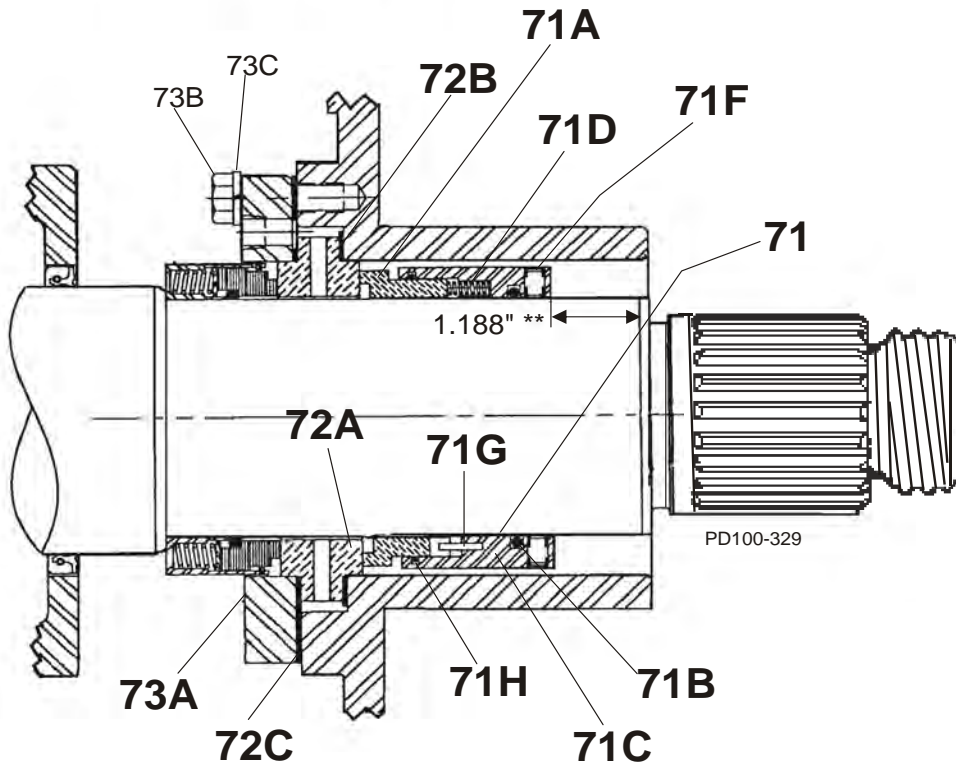

** Waukesha HD/Crane 8B2 shown. Contact factory and provide serial # to correctly identify the pump seal provided.

PD Pump Seals Model 320-323A-324-UI

ITEM NO.	DESCRIPTION	QTY. PER PUMP	PART NO.	NOTES
	OUTER SEAL			
* 70	Crane #8B2 Outer Seal, Carbon	2	323 114 003+	30
* 70B	O-Ring, Outer Seal, Shaft, EPDM	2	E70234	
* 70B	O-Ring, Outer Seal, Shaft, FKM	2	V70234	
* 70B	O-Ring, Outer Seal, Shaft, Silicone	2	S75234	
* 72	"T" Seat, Plain, Ceramic	2	300 014 012+	
* 72	"T" Seat, Plain, Tungsten Carbide	2	300 014 013+	
* 72	"T" Seat, Plain, Silicon Carbide	2	300 014 016+	
* 72B, 72C	Gasket, Inner and Outer	4	300 042 001+	
73	Gland, Plain	2	300 034 001 +	
73B	3/8-16 x 1-1/4" HHCS	8	30-60	
73C	Lockwasher, 3/8"	8	43-28	
	INNER SEAL			
* 71	Waukesha HD Inner Seal, Silicon Carbide	2	40572+	16
* 71	Waukesha HD Inner Seal, Ceramic	2	40573+	16
* 71	Waukesha HD Inner Seal, Chrome Oxide	2	40574+	16
* 71A	Seal Face, Silicon Carbide	2	40754+	
* 71A	Seal Face, Ceramic	2	40755+	
* 71A	Seal Face, Chrome Oxide	2	40756+	
* 71A	Seal Face, Tungsten Carbide	2	109347+	
* 71A	Seal Face, Carbon	2	36027+	
* 71B	O-Ring, Inner Seal, Shaft, EPDM	2	E70234	
* 71B	O-Ring, Inner Seal, Shaft, FKM	2	V70234	
* 71B	O-Ring, Inner Seal, Shaft, Silicone	2	S75234	
* 71D	Spring	12	40875+	
* 71F	Set Screw	8	110038+	
* 71H	O-Ring, Inner Seal, Seal Face, EPDM	2	E70238	
* 71H	O-Ring, Inner Seal, Seal Face, FKM	2	V70238	
* 71H	O-Ring, Inner Seal, Seal Face, Silicone	2	S75238	
	INNER - OUTER SEAL			
71C	Carrier Inner Sub-Assembly	2	35284+	
* 72A	"T" Seat, Flushed, Ceramic	2	300 014 027+	
* 72A	"T" Seat, Flushed, Tungsten Carbide	2	300 014 028+	
* 72A	"T" Seat, Flushed, Chrome Oxide	2	300 014 029+	
* 72A	"T" Seat, Flushed, Silicon Carbide	2	300 014 031+	
* 72B	Gasket, Inner	2	300 042 001+	
* 72C	Gasket, Flushed Gland, Outer	2	300 042 002+	
73A	Gland, Flushed	2	300 034 001+	
73B	3/8-16 x 1-1/4" HHCS	8	30-60	
73C	3/8" Lockwasher	8	43-28	

NOTES:

PL5060-CH62

16. Complete Inner Seal supplied with Silicon Rubber o-rings. Buna, EPDM, FKM O-Rings also available--contact factory for information.
30. Alternate materials available. Standard is listed. Contact factory for information.

* **Recommended Spare Parts**

Tru-Fit™ Universal I PD Pumps Parts List

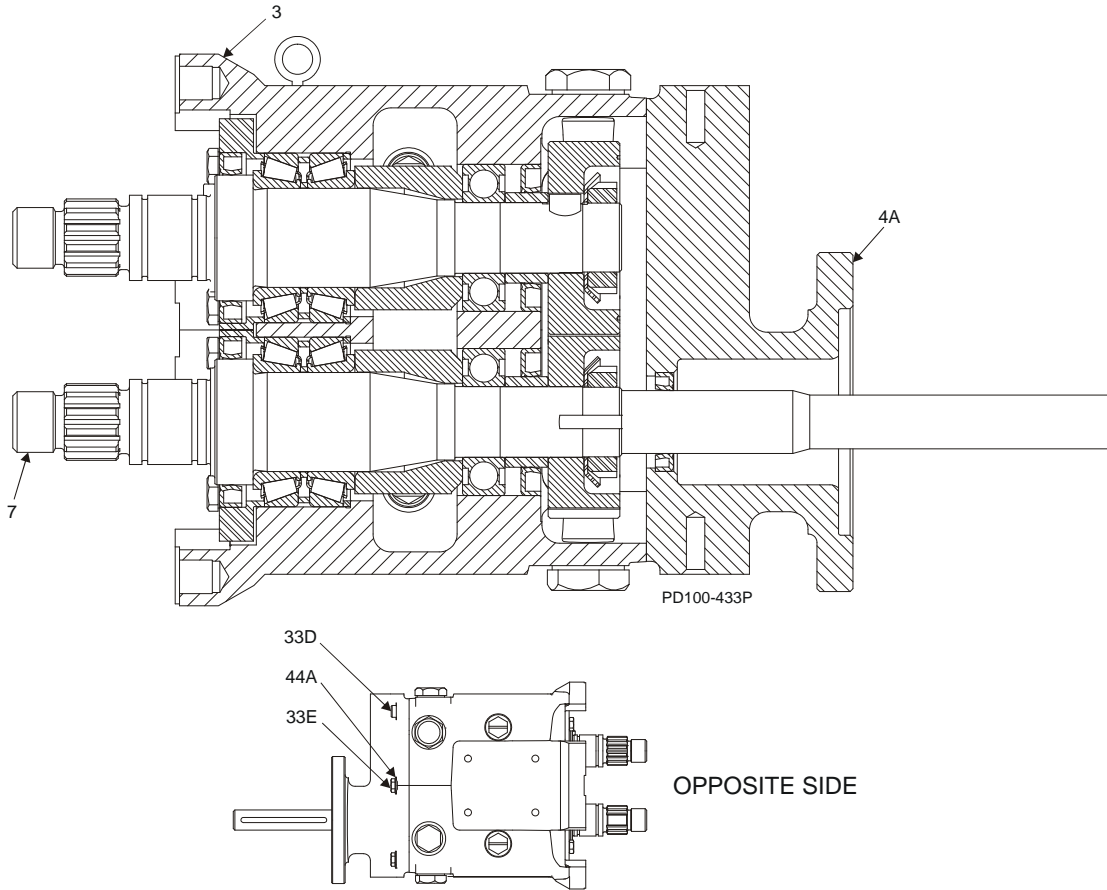

ITEM NO.	DESCRIPTION	Pump Size			
		006, 014, 015	018, 024	030, 034	040
3	Gear Case, CI	118986+		121687+	
4A	Gear Case Cover, Adapter	118982+		118678+	
7	Drive Shaft	119174+	119175+	119176+	119177+
33D	1/4-20 x 1" HHCS	30-93		N/A	
	5/16-18 x 1-1/8" HHCS	N/A		30-237	
33E	5/16" x 3/4" lg. SHSB	30-690		N/A	
	3/8" x 3/4" lg. SHSB	N/A		30-691	
44A	Flat Washer, 5/16"	43-246		N/A	
	Flat Washer, 3/8"	N/A		43-30	

ITEM NO.	DESCRIPTION	Pump Size			
		060, 064	130, 134	220, 224	320, 324
3	Gear Case, CI	118987+		118988+	118989+
4A	Gear Case Cover, Adapter	118983+		S/N Req'd	
7	Drive Shaft	119178+	119179+	119180+	119181+
33D	3/8-16 x 1-1/2" HHCS	30-50			N/A
	1/2-13 x 1-1/2" HHCS	N/A			30-103
33E	1/2" x 1" lg. SHSB	30-692			N/A
	5/8" x 1" lg. SHSB	N/A			30-693
44A	Flat Washer, 1/2"	43-31			

Note:

Item 12 is not included with item 4A; it is re-used from the existing gearcase seal.
See Common Parts lists/diagrams on previous pages for the various pump models.

PL5060-CH65

Grease Seal, Bearing Retainer, O-Ring Seal Carrier Part Number Reference

UI Model Number	Description	Part # before 7/12/04 (OLD)	Part # after 7/12/04 (NEW)
006, 014, 015, 018, 024			
	Grease Seal, Bearing Retainer	101716+	121679+
	Bearing Retainer, Front	101810+	120332+
	O-Ring Seal Carrier	015034000+	015034001+
030, 034, 040			
	Grease Seal, Bearing Retainer	N/A	121680+
	Bearing Retainer, Front	101811+	120333+
	O-Ring Seal Carrier	030034000+	030034001+
060, 064, 130, 134			
	Bearing Retainer, Front STD	N/A	123531+
	Bearing Retainer, Front SS	101812+	121828+
	O-Ring Seal Carrier	060034000+	060034001+
220, 224			
	Grease Seal, Bearing Retainer	N/A	121681+
	Bearing Retainer, Front STD	220080000+	123532+
	Bearing Retainer, Front SS	101813+	121829+
	O-Ring Seal Carrier	220034000+	220034001+
320, 324			
	Grease Seal, Bearing Retainer	N/A	121681+
	Bearing Retainer, Front STD	0H1080000	123533+
	Bearing Retainer, Front SS	118365+	123533+

PL5060-CH114

Special Tools

Offset Rotor Wrench

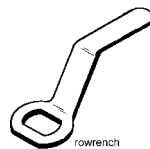

Model	Part Number
006-024-UI	AD0019001
030-040-UI	CD0019001
060-134-U1	060019001+

Pump Dimensions

Universal I PD Pump Dimensions

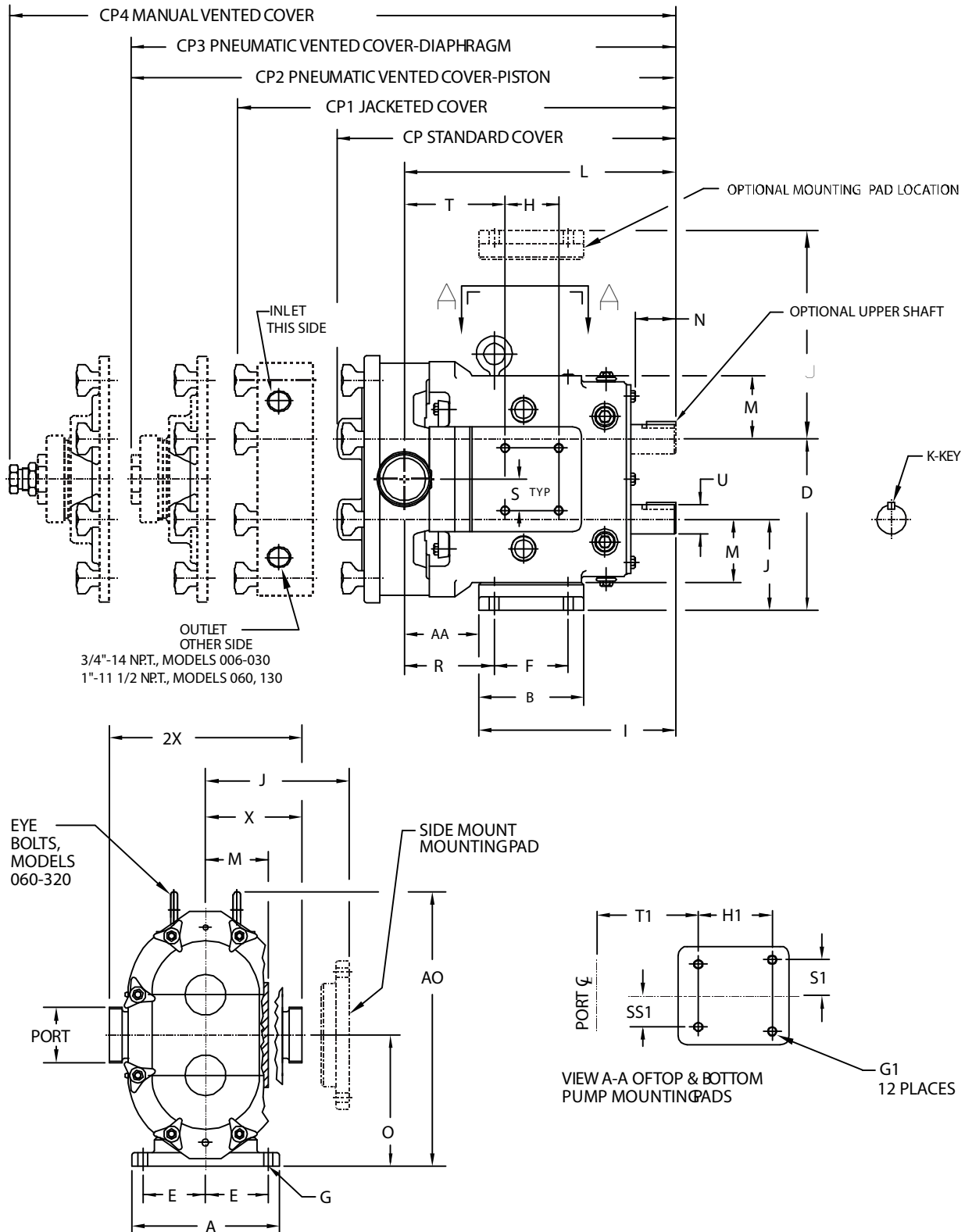

Universal I PD Pump Dimensions

UI Model		A	AA	AO	B	CP	CP1	CP2	CP3	CP4	D	E	F	G	G1	H	H1	I
006, 015	inch	4.75	1.95	8.30	3.75	12.04	13.47	13.53	13.62	15.25	5.50	1.94	2.31	.41, SLOT	5/16-18x.62	2.50	2.50	7.66
	mm	121	50	211	95	306	342	344	346	387	140	49	59	10, SLOT	--	64	64	194
018	inch	4.75	2.18	8.30	3.75	12.46	13.90	13.95	14.04	15.67	5.50	1.94	2.31	.41, SLOT	5/16-18x.62	2.50	2.50	7.66
	mm	121	55	211	95	316	353	354	357	398	140	49	59	10, SLOT	--	64	64	194
030	inch	6.25	2.78	10.29	4.25	14.58	16.42	15.98	16.07	17.67	6.86	2.31	2.56	.41, SLOT	3/8-16x.62	1.81	2.75	8.83
	mm	159	71	261	108	370	417	406	408	449	174	59	65	10, SLOT	--	46	770	224
040	inch	6.25	2.99	10.29	4.25	14.96	16.80	16.36	16.45	18.05	6.86	2.31	2.56	.41, SLOT	3/8-16x.62	1.81	2.75	8.83
	mm	159	76	261	108	380	427	416	418	458	174	59	65	10, SLOT	--	46	70	224
060	inch	8.25	4.14	15.31	5.87	18.91	20.69	20.47	20.76	22.07	9.56	3.50	4.12	.53	1/2-13x.88	3.00	4.13	10.99
	mm	210	105	389	149	480	526	520	527	561	243	89	105	13	--	76	105	279
130	inch	8.25	4.78	15.31	5.87	19.85	21.63	21.42	21.70	23.01	9.56	3.50	4.12	.53	1/2-13x.88	3.00	4.13	10.99
	mm	210	121	389	149	504	549	544	551	584	243	89	105	13	--	76	105	279
220	inch	8.5	3.69	19.13	9.00	23.37	--	26.07	--	27.87	12.38	3.75	7.25	.53, SLOT	1/2-13x1.00	5.38	5.38	14.80
	mm	216	94	486	229	594	--	662	--	708	314	95	184	13, SLOT	--	137	137	376
320	inch	12.00	4.12	22.38	11.63	30.17	--	--	--	--	13.88	5.25	8.00	.66	1/2-13x1.00	5.38	5.38	17.80
	mm	305	105	568	295	766	--	--	--	--	353	133	203	17	--	137	137	452

UI Model		J	K +.002 -.000	L	M	N	O	Port	R	S	S1	SS1	T	T1	U +.002 -.000	X	2X	WT*
006, 015	inch	2.93	.1875	9.61	2.12	2.00	4.21	1-1/2" IMDA	2.79	1.00	1.00	1.00	2.51	2.51	.875	3.49	6.97	24 lb
	mm	74	4.763	244	54	51	107	--	71	25	25	25	64	64	22.23	89	177	52 kg
018	inch	2.93	.1875	9.84	2.12	2.00	4.21	1-1/2" IMDA	3.02	1.00	1.00	1.00	2.74	2.74	.875	3.55	7.09	24 lb
	mm	74	4.763	250	54	51	107	--	77	25	25	25	70	70	22.23	90	180	54 kg
030	inch	3.56	.25	11.61	2.62	2.32	5.21	1-1/2" IMDA	3.84	1.12	1.12	1.12	4.00	3.59	1.250	4.25	8.50	45 lb
	mm	90	6.35	295	67	59	132	--	98	28	28	28	102	91	31.75	108	216	100 kg
040	inch	3.56	.25	11.99	2.62	2.32	5.21	2" IMDA	4.22	1.12	1.12	1.12	4.38	3.97	1.250	4.31	8.62	48 lb
	mm	90	6.35	305	67	59	132	--	107	28	28	28	111	101	31.75	109	219	106 kg
060	inch	5.06	.375	15.14	3.50	2.25	7.31	2-1/2" IMDA	5.01	1.75	2.00	1.75	5.62	5.01	1.625	5.37	10.75	116 lb
	mm	129	9.525	385	89	57	186	--	127	44	51	44	143	127	41.28	136	273	255 kg
130	inch	5.06	.375	15.77	3.50	2.25	7.31	3" IMDA	5.65	1.75	2.00	1.75	6.25	5.66	1.625	5.37	10.75	118 lb
	mm	129	9.525	401	89	57	186	--	144	44	51	44	159	144	41.28	136	273	260 kg
220	inch	6.38	.50	18.49	4.50	2.75	9.38	4" IMDA	4.44	2.69	2.69	2.69	6.00	6.00	2.000	6.63	13.25	204 lb
	mm	162	12.7	470	114	70	238	--	113	68	68	68	152	152	50.80	168	337	450 kg
320	inch	6.88	.625	21.92	5.06	4.06	10.38	6" 150# FLG	5.37	2.69	2.69	2.69	8.49	8.49	2.375	8.00	16.00	361 lb
	mm	175	15.875	557	129	103	264	--	136	68	68	68	213	213	60.45	203	406	795 kg

PD100-437c

Notes

* WT = Standard Cover

IMDA ports are standard; other laser-welded ports are available for models 006 through 220.

Universal I PD Pump Dimensions - Rectangular Flange with Pedestal

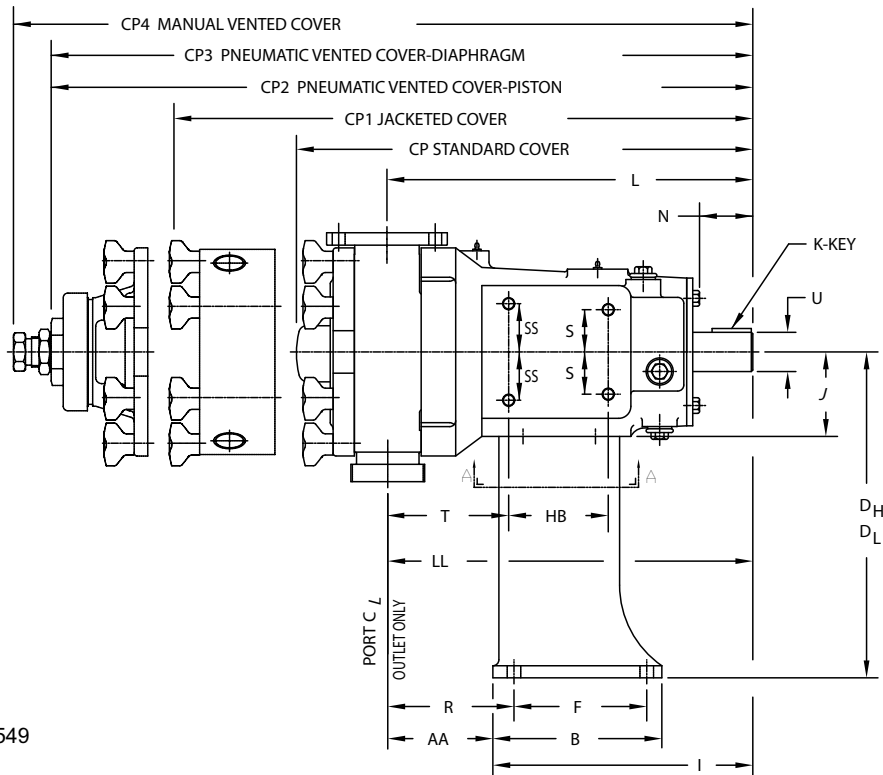
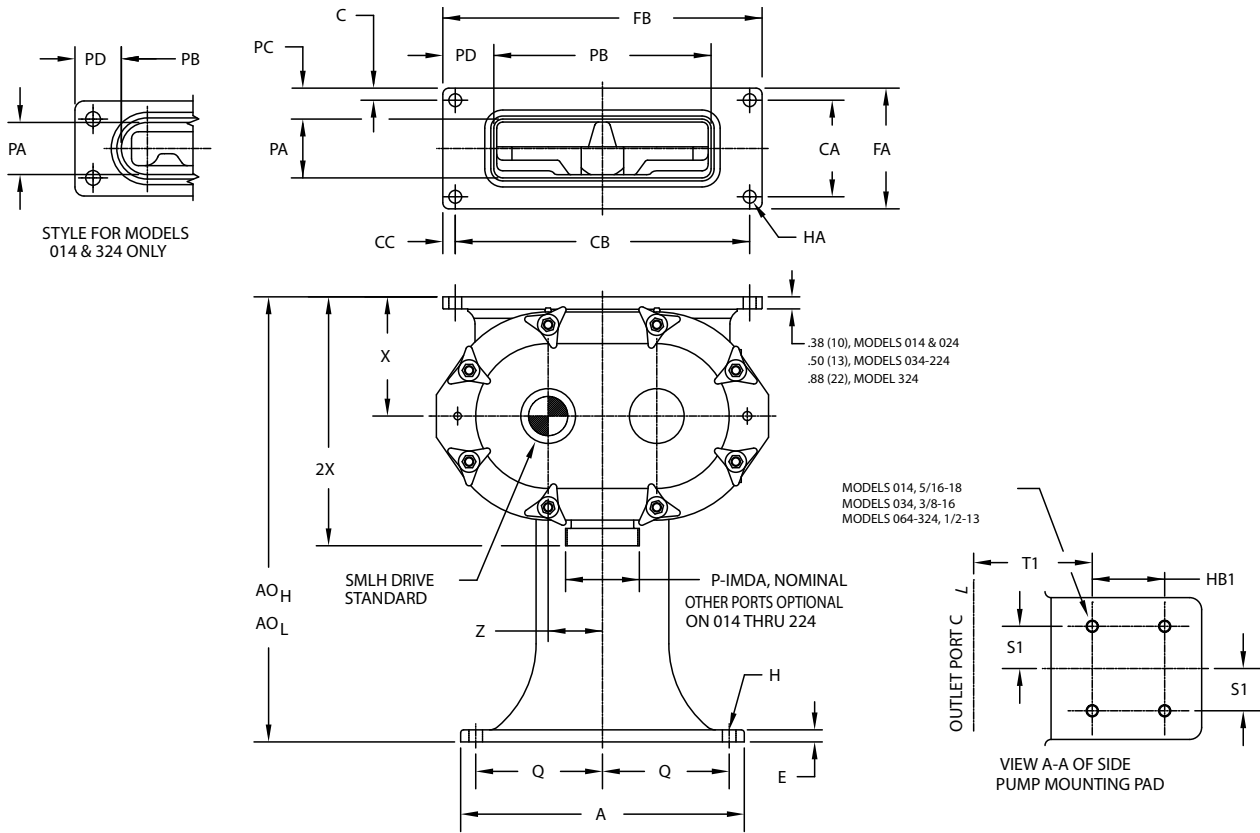

PD100-549

Universal I PD Pump Dimensions - Rectangular Flange with Pedestal

UI RF Model		A	AA	AO _H	AO _L	B	C	CA	CB	CC	CP	CP1	CP2	CP3	CP4	D _H	D _L	E	F	FA	FB	H	HA	HB	HB1
014	inch	6.75	1.95	-	12.50	4.13	.50	1.62	6.50	.50	12.04	13.47	13.53	13.62	15.25	-	8.88	.38	2.31	2.63	7.50	.41	.41	2.50	2.50
	mm	171	50	-	318	105	13	41	165	13	306	342	344	346	387	-	226	10	59	67	191	10	10	64	64
024	inch	6.75	2.18	-	12.50	4.13	.50	2.00	7.00	.50	12.46	13.9	13.95	14.04	15.67	-	8.88	.38	2.31	3.00	8.00	.41	.41	2.50	2.50
	mm	171	55	-	318	105	13	51	178	13	316	353	354	357	398	-	226	10	59	76	203	10	10	64	64
034	inch	8.00	2.88	-	12.75	4.25	.62	1.88	10.75	.62	14.58	16.42	15.98	16.07	17.67	-	8.88	.38	3.00	3.12	12.0	.44	.53	2.75	1.81
	mm	203	73	-	324	108	16	48	273	16	370	417	406	408	449	-	226	10	76	79	305	11	13	70	46
064	inch	11.75	4.35	18.44	13.94	7.00	.50	4.00	12.20	.52	18.91	20.69	20.47	20.76	22.07	13.5	9.00	.50	5.550	5.00	13.23	.56	.53	7.13	3.00
	mm	298	110	468	354	178	13	102	310	13	480	526	520	527	561	343	229	13	140	127	336	14	13	105	76
134	inch	11.75	5.00	18.44	13.94	7.00	.78	3.00	14.00	0.63	19.85	21.63	21.42	21.7	23.01	13.5	9.00	.50	5.50	4.55	15.25	.56	.53	4.13	3.00
	mm	298	127	468	354	178	20	76	356	16	504	549	544	551	584	343	229	13	140	116	387	14	13	105	76
224	inch	15.00	4.75	23.75	19.75	9.50	.63	4.37	16.75	.63	23.37	-	26.07	-	27.87	17.5	13.50	.63	8.25	5.63	18.00	.56	.53	5.38	5.38
	mm	381	121	603	502	241	16	111	425	16	594	-	662	-	708	445	343	16	210	143	457	14	13	137	137
324	inch	18.00	6.56	-	36.00	12.00	.63	8.25	18.50	.69	30.17	-	-	-	-	-	27.13	.75	9.50	9.50	19.88	.69	.66	5.38	5.38
	mm	457	167	-	914	305	16	210	470	18	766	-	-	-	-	-	689	19	241	241	505	18	17	137	137

UI RF Model		I	J	K +.002 -.000	L	LL	N	P	PA	PB	PC	PD	Q	R	S	S1	SS	T	T1	U +.002 -.000	X	2X	Z	Port Size	WT*
014	inch	7.66	2.12	.1875	9.61	9.61	2.00	1.5	1.44	4.94	.59	1.28	2.81	2.79	1.00	1.00	1.00	2.51	2.51	.875	3.63	7.11	1.28	1-1/2"	47 kg
	mm	195	54	4.763	244	244	51	-	37	125	15	33	71	71	25	25	25	64	64	22.23	92	181	33	--	21 lb
024	inch	7.66	2.12	.1875	9.84	9.84	2.00	1.5	1.75	5.13	.63	1.44	2.81	3.02	1.00	1.00	1.00	2.74	2.74	.875	3.63	7.11	1.28	1-1/2"	49 kg
	mm	195	54	4.763	250	250	51	-	44	130	16	37	71	77	25	25	25	70	70	22.23	92	181	33	--	22 lb
034	inch	8.49	2.63	.25	11.36	11.37	2.32	2.0	1.84	6.84	.66	2.58	3.38	3.51	1.12	1.12	1.12	3.35	3.76	1.250	3.88	8.12	1.65	2"	100 kg
	mm	216	67	6.35	289	289	59	-	46	174	17	66	86	89	28	28	28	85	96	31.75	99	206	42	--	45 lb
064	inch	10.77	3.50	.375	15.16	15.12	2.25	2.5	2.44	9.00	1.28	2.11	5.25	5.23	2.00	1.75	1.75	5.01	5.60	1.625	4.94	10.31	2.25	2-1/2"	255 kg
	mm	274	89	9.525	385	384	57	-	62	229	33	54	133	133	51	44	44	127	142	41.28	125	262	57	--	116 lb
134	inch	10.77	3.50	.375	15.78	15.76	2.25	3.0	3.19	9.37	.68	2.94	5.25	5.87	2.00	1.75	1.75	5.65	6.25	1.625	4.94	10.31	2.25	3"	280 kg
	mm	274	89	9.525	401	400	57	-	81	238	17	75	133	149	51	44	44	144	159	41.28	125	262	57	--	127 lb
224	inch	13.74	4.50	.50	18.49	18.49	2.75	4.0	4.06	11.25	.78	3.38	3.88	5.37	2.69	2.69	2.69	6.00	6.00	2.000	6.25	12.87	3.00	4"	505 kg
	mm	349	114	12.70	470	470	70	-	103	286	20	86	175	136	68	68	68	152	152	50.80	159	327	76	--	229 lb
324	inch	16.86	5.06	.625	23.42	23.42	4.06	6.0	5.00	17.38	2.25	1.25	7.75	7.81	2.69	2.69	2.69	9.87	9.87	2.375	8.87	17.88	3.50	6" 150# FLG	775 kg
	mm	428	129	15.875	595	595	103	-	127	441	57	32	197	198	68	68	68	251	251	60.33	225	454	89	--	352 lb

Notes

*WT Weight measurement is with Standard Cover with Standard Universal Foot
 Model 324 has 8 bolt holes in rectangular flange. Outlet port is a round flange.
 Dimension AO is with the tallest pedestal. Optional heights are available.
 CP4 is the maximum dimension for all vented and jacketed cover options.

PD100-437b

Tru-Fit™ Universal I PD Pump Dimensions

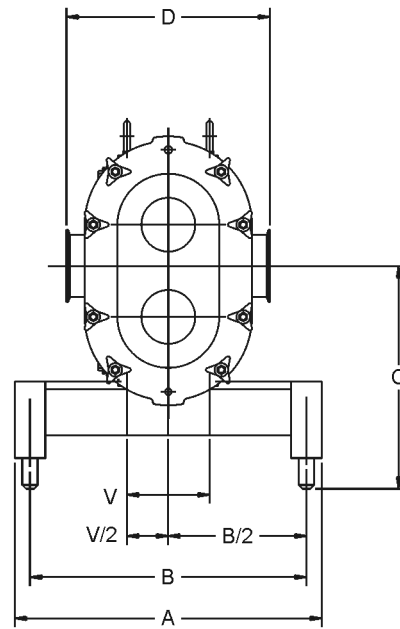
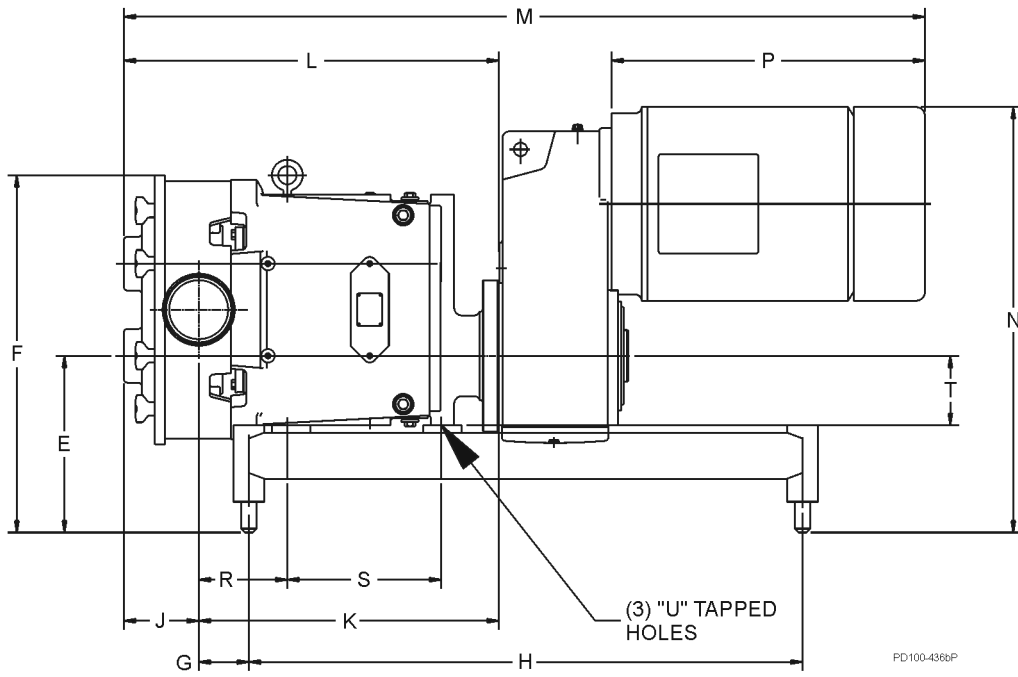

Tru-Fit™ Universal I PD Pump Dimensions

Tru-Fit™ Universal I Pump Size		A	B	C	D ²	E	F	G	H	J	K
006	inch	12.0	10.0	9.15	6.97	7.87	13.25	2.01	18.0	2.43	10.08
	mm	305	254	232	177	200	337	51	457	62	256
015	inch	12.0	10.0	9.15	6.97	7.87	13.25	2.01	18.0	2.43	10.08
	mm	304	254	232	177	200	337	51	457	62	256
018	inch	12.0	10.0	9.15	7.10	7.87	13.25	2.25	18.0	2.62	10.31
	mm	304	254	232	180	200	337	57	457	67	262
030	inch	14.0	12.0	10.02	8.51	8.37	15.11	2.59	20.0	2.97	12.47
	mm	356	304	255	216	213	384	66	508	75	317
040	inch	14.0	12.0	10.02	8.62	8.37	15.11	2.97	20.0	2.97	12.84
	mm	356	305	255	219	213	384	75	508	75	326
060	inch	18.0	16.0	12.0	10.74	9.75	20.0	3.01	28.0	3.77	17.39
	mm	457	406	305	273	248	508	76	711	96	442
130	inch	18.0	16.0	12.0	10.74	9.75	20.0	3.64	28.0	4.08	18.02
	mm	457	406	305	273	248	508	92	711	104	458
220	inch	20.0	18.0	14.5	13.25	11.5	23.25	3.51	36.0	4.99	19.76
	mm	508	457	368	337	292	591	89	914	127	502

Tru-Fit™ Universal I Pump Size		L	M ¹	N ¹	P ¹	Port Size	R	S	T	U	V
006	inch	12.51	27.60	15.56	10.92	1-1/2"	2.79	5.44	2.12	5/16-18 x .62	2.00
	mm	318	701	395	227	--	71	138	54	N/A	51
015	inch	12.51	27.60	15.56	10.92	1-1/2"	2.79	5.44	2.12	5/16-18 x .62	2.00
	mm	318	701	395	227	--	71	138	54	N/A	51
018	inch	12.93	28.02	15.56	10.92	1-1/2"	3.02	5.44	2.12	5/16-18 x .62	2.00
	mm	328	712	395	227	--	77	138	54	N/A	51
030	inch	15.44	33.67	18.65	13.74	1-1/2"	3.84	5.81	2.62	3/8-16 x .62	2.25
	mm	392	855	474	349	--	98	148	67	N/A	57
040	inch	15.81	34.04	18.65	13.74	2"	4.22	5.81	2.62	3/8-16 x .62	2.25
	mm	402	865	474	349	--	107	148	67	N/A	57
060	inch	21.16	43.77	22.02	17.16	2-1/2"	5.01	8.13	3.50	1/2-13 x .88	3.50
	mm	537	1112	559	436	--	127	207	89	N/A	89
130	inch	22.10	44.71	22.02	17.16	3"	5.65	8.13	3.50	1/2-13 x .88	3.50
	mm	561	1136	559	436	--	144	207	89	N/A	89
220	inch	24.51	52.23	25.91	18.82	4"	4.73	10.00	4.50	1/2-13 x 1.0	5.38
	mm	623	1327	658	478	--	120	254	114	N/A	137

PD100-437

Troubleshooting

PROBLEM	POSSIBLE CAUSE	SUGGESTED ACTION
No flow, pump rotors are not turning	Drive motor not running.	Check resets, fuses, circuit breakers.
	Keys sheared or missing.	Replace.
	Drive belts, power transmission components slipping or broken.	Replace or adjust.
	Pump shaft, keys, or gears sheared.	Inspect: and replace parts as necessary.
No flow, pump rotors are turning	Rotors turn in the wrong direction.	Check motor hookup to reverse motor rotation.
	Relief valve not properly adjusted, or held open by foreign material.	Adjust or clear valve.
	Suction port is blocked, not allowing flow to the pump.	Check all inlet valves, strainers, tank outlet ports.
No flow, pump not priming	Valve closed in inlet line.	Open valve.
	Inlet line clogged or restricted.	Clear line, clean filters, etc.
	Air leaks due to bad gaskets or pipe connections.	Replace gaskets; check lines for leakage (can be done by air pressure or by filling with liquid and pressurizing with air).
	Pump speed too slow.	Increase pump speed.
	Pump speed too fast for high-viscosity liquid.	Decrease pump speed.
	Liquid drains or siphons from system during off periods.	Use foot valve or check valves. Filling inlet lines with material before startup may solve startup priming problems due to no material in system.
	"Air" lock caused by fluids which "gas off", or vaporize, or allow gas to come out of solution during off periods.	Install and use a manual or automatic air bleed from pump or lines near pump.
	Extra clearance rotors, worn pump.	Increase pump speed, use foot valve to improve priming. Replace worn rotors.
	Net inlet pressure available too low.	Check Net Inlet Pressure Available & Net Inlet Pressure Required. Change inlet system as needed.

PROBLEM	POSSIBLE CAUSE	SUGGESTED ACTION
No flow, pump not priming, cont'd	On "Vacuum" inlet system: On initial start-up, atmospheric "blow back" prevents pump from developing enough differential pressure to start flow.	Install check valve in discharge line.
Insufficient flow	Speed too low or too high to obtain desired flow.	Check flow-speed curve (available from WCB customer service) and adjust as necessary.
	Air leak due to bad seals, pipe connections, or other equipment.	Replace seals, check inlet fittings.
Insufficient flow—flow being bypassed somewhere	Flow diverted in branch line, open valve, etc.	Check system and controls
	Relief valve not adjusted or jammed.	Clear or adjust valve.
Insufficient flow—high slip	Hot (HC) or extra clearance rotors on "cold" fluid and/or low viscosity fluid.	Replace with standard clearance rotors.
	Worn pump.	Increase pump speed (within limits). Replace rotors, have pump remanufactured.
	High pressure.	Reduce pressure by adjusting system settings or hardware.
Fluid vaporization ("starved" pump inlet)	Strainers, foot valves, inlet fittings or lines clogged.	Clear lines. If problem continues, inlet system may require changing.
	Inlet line size too small, inlet line too long. Too many fittings or valves. Foot valve, strainers too small.	Increase inlet line size. Reduce length, minimize direction and size changes, reduce number of fittings.
	NIPA - Net Inlet Pressure Available at Pump is too low.	Raise liquid level in source tank to increase Net Inlet Pressure (NIPA). Increase Net Inlet Pressure Available at Pump by raising or pressurizing source tank.
		Select larger pump size with lower Net Inlet Pressure Required.
	Fluid viscosity greater than expected.	Reduce pump speed and accept lower flow, or change system to reduce line losses. Change temperature of product to reduce viscosity.

PROBLEM	POSSIBLE CAUSE	SUGGESTED ACTION
Fluid vaporization, cont'd	Fluid temperature higher than expected (vapor pressure higher).	Reduce temperature, reduce speed and accept lower flow or change system to increase Net Inlet Pressure Available.
Noisy operation	Cavitation	
	High fluid viscosity. High vapor pressure fluid. High temperature.	Slow down pump, reduce temperature, change system setup.
	Net Inlet Pressure Available less than Net Inlet Pressure Required.	Increase NIPA - Net Inlet Pressure Required or reduce NIPR - Net Inlet Pressure Required. Contact WCB customer service if necessary.
	Air or gas in fluid	
	Leaks in the pump or piping.	Correct leaks.
	Dissolved gas or naturally aerated products.	Minimize discharge pressure (also see "Cavitation," above).
Noisy operation caused by mechanical problems	Rotor to body contact	
	Improper assembly of pump.	Check clearances and adjust shimming.
	Distortion of pump due to improper piping installation.	Change piping installation to eliminate piping stress and distortion on body.
	Pressures required higher than the pump is rated for.	Reduce discharge pressure required.
	Worn bearings.	Rebuild with new bearings and lubricate regularly.
	Rotor to Rotor Contact	
	Loose or incorrectly-timed gears.	This has caused severe damage to components - rebuild with new parts.
	Sheared keys.	This has caused severe damage to components - rebuild with new parts.
Worn gear splines.	This has caused severe damage to components - rebuild with new parts.	
Drive noise caused by gear trains, chains, couplings, bearings.	Repair or replace drive parts. Check bearings for damage and replace as necessary.	

PROBLEM	POSSIBLE CAUSE	SUGGESTED ACTION
Pump requires excessive power (overheats, stalls, high current draw, breakers trip)	Higher than expected viscosity losses.	If within pump rating, increase drive size.
	Higher than expected pressures.	Reduce pump speed. Increase line sizes.
	Fluid is colder with a higher viscosity than expected.	Heat fluid, insulate lines or heat trace lines. Increase line sizes.
	Fluid sets in line and pump during shutdown.	Insulate lines or heat trace lines. Install a "soft start" drive. Install a recirculating bypass system. Flush system with a nonsetting fluid.
	Fluid builds up on pump surfaces.	Replace the pump with more running clearances.
Short pump service life	Pumping abrasives	Larger pumps at slower speeds.
	Speeds and pressures higher than rated.	Reduce speeds and pressures by making changes in the system. Replace pump with a larger model with higher pressure ratings.
	Worn bearings and gears due to lack of lubrication.	Check and replace bearing and gears as necessary. Adjust lubrication schedule to decrease time between lubrication. Modify external wash down method to reduce water entering into gear case.
	Misalignment of drive and piping. (Excessive overhung load or misaligned couplings.)	Check alignment of piping and drive. Adjust as necessary.

Universal I Maintenance Summary Reference Sheet

Universal I Model	Change oil every 750 hours* ISO Grade 320, SAE 140 or AGMA Number 6EP		Grease bearings every 750 hours* NLGI Grade No. 2, EP, Lithium-based grease.	
	<i>* Aggressive washdown or extreme running conditions may require more frequent lubrication intervals.</i>			
	Oil Capacity (Gears)		Grease Quantity (per Bearing)	
	Top or Bottom	Side Mount	Front	Rear
006, 014, 015, 018, 024	1.3 oz (40 ml)	3.3 oz (100 ml)	0.37 oz (11 cc)	0.13 oz (4 cc)
030, 033A, 034, 040	2.0 oz (60 ml)	4 oz (120 ml)	0.60 oz (18 cc)	0.21 oz (6 cc)
060, 064, 130, 133A, 134	6.0 oz (170 ml)	9.5 oz (280 ml)	0.84 oz (25 cc)	0.76 oz (22 cc)
220, 223A, 224	11 oz (320 ml)	20 oz (600 ml)	1.33 oz (39 cc)	1.03 oz (30 cc)
320, 323A, 324	17 oz (500 ml)	44 oz (1300 ml)	1.96 oz (58 cc)	1.16 oz (34 cc)

Universal I Model	Wrench Size
	Body Retaining Cap Screw
006, 014, 015, 018, 024, 030, 033A, 034, 040	3/16"
060, 064, 130, 133A, 134	1/4"
220, 223A, 224, 320, 323A, 324	5/16"

Universal I Model	Rotor Clearance - Standard and Hot Clearance Rotors						
	Rotor:	A - Back Face in (mm)		B - Rotor to Body in (mm)		C - Front Face in (mm)	
		Standard	Hot	Standard	Hot	Standard	Hot
006, 014, 015, 018, 024, 030, 034, 040	.002 (.05 mm)		.002 - .003 (.05 - .08 mm)	.0035 - .0045 (.09 - .11 mm)	.004 - .0065 (.10 - .17 mm)	.006 - .008 (.15 - .20 mm)	
033A	.002 (.05 mm)		.002 - .004 (.05 - .10 mm)	.0035 - .005 (.09 - .13 mm)	.0035 - .006 (.09 - .15 mm)	.0065 - .009 (.17 - .23 mm)	
060, 064, 133A, 130, 134	.003 - .0035 (.08 - .09 mm)		.004 - .0065 (.10 - .17 mm)	.006 - .009 (.15 - .23 mm)	.0045 - .009 (.11 - .23 mm)	.0085 - .015 (.22 - .38 mm)	
220, 223A, 224	.004 - .005 (.10 - .13 mm)		.0065 - .0085 (.17 - .22 mm)	.010 - .012 (.25 - .30 mm)	.005 - .010 (.13 - .25 mm)	.010 - .015 (.25 - .38 mm)	
320, 323A, 324	.005 - .006 (.13 - .15 mm)		.009 - .011 (.23 - .28 mm)	.011 - .013 (.28 - .33 mm)	.007 - .012 (.18 - .30 mm)	.013 - .018 (.33 - .46 mm)	

NOTE: Standard Rotors: -40°F (-40°C) to 200°F (93°C); Hot Clearance Rotors: -40°F (-40°C) to 300°F (149°C). Contact Waukesha Cherry-Burrell Application Engineering if alternate rotors are needed.

**Universal I Maintenance Summary Reference Sheet -
Copy for optional removal**

Universal I Model	Change oil every 750 hours* ISO Grade 320, SAE 140 or AGMA Number 6EP		Grease bearings every 750 hours* NLGI Grade No. 2, EP, Lithium-based grease.	
	<i>* Aggressive washdown or extreme running conditions may require more frequent lubrication intervals.</i>			
	Oil Capacity (Gears)		Grease Quantity (per Bearing)	
	Top or Bottom	Side Mount	Front	Rear
006, 014, 015, 018, 024	1.3 oz (40 ml)	3.3 oz (100 ml)	0.37 oz (11 cc)	0.13 oz (4 cc)
030, 033A, 034, 040	2.0 oz (60 ml)	4 oz (120 ml)	0.60 oz (18 cc)	0.21 oz (6 cc)
060, 064, 130, 133A, 134	6.0 oz (170 ml)	9.5 oz (280 ml)	0.84 oz (25 cc)	0.76 oz (22 cc)
220, 223A, 224	11 oz (320 ml)	20 oz (600 ml)	1.33 oz (39 cc)	1.03 oz (30 cc)
320, 323A, 324	17 oz (500 ml)	44 oz (1300 ml)	1.96 oz (58 cc)	1.16 oz (34 cc)

Universal I Model	Wrench Size
	Body Retaining Cap Screw
006, 014, 015, 018, 024, 030, 033A, 034, 040	3/16"
060, 064, 130, 133A, 134	1/4"
220, 223A, 224, 320, 323A, 324	5/16"

Universal I Model	Rotor Clearance - Standard and Hot Clearance Rotors					
	A - Back Face in (mm)		B - Rotor to Body in (mm)		C - Front Face in (mm)	
	Standard	Hot	Standard	Hot	Standard	Hot
Rotor:						
006, 014, 015, 018, 024, 030, 034, 040	.002 (.05 mm)		.002 - .003 (.05 - .08 mm)	.0035 - .0045 (.09 - .11 mm)	.004 - .0065 (.10 - .17 mm)	.006 - .008 (.15 - .20 mm)
033A	.002 (.05 mm)		.002 - .004 (.05 - .10 mm)	.0035 - .005 (.09 - .13 mm)	.0035 - .006 (.09 - .15 mm)	.0065 - .009 (.17 - .23 mm)
060, 064, 133A, 130, 134	.003 - .0035 (.08 - .09 mm)		.004 - .0065 (.10 - .17 mm)	.006 - .009 (.15 - .23 mm)	.0045 - .009 (.11 - .23 mm)	.0085 - .015 (.22 - .38 mm)
220, 223A, 224	.004 - .005 (.10 - .13 mm)		.0065 - .0085 (.17 - .22 mm)	.010 - .012 (.25 - .30 mm)	.005 - .010 (.13 - .25 mm)	.010 - .015 (.25 - .38 mm)
320, 323A, 324	.005 - .006 (.13 - .15 mm)		.009 - .011 (.23 - .28 mm)	.011 - .013 (.28 - .33 mm)	.007 - .012 (.18 - .30 mm)	.013 - .018 (.33 - .46 mm)

NOTE: Standard Rotors: -40°F (-40°C) to 200°F (93°C); Hot Clearance Rotors: -40°F (-40°C) to 300°F (149°C). Contact Waukesha Cherry-Burrell Application Engineering if alternate rotors are needed.

Notes



Universal I Series

ROTARY POSITIVE DISPLACEMENT
PUMP

SPX FLOW

SPX FLOW, Inc.

611 Sugar Creek Road

Delavan, WI 53115

P: (262) 728-1900 or (800) 252-5200

F: (262) 728-4904 or (800) 252-5012

E: wcb@spxflow.com

SPX FLOW, Inc. reserves the right to incorporate our latest design and material changes without notice or obligation.

Design features, materials of construction and dimensional data, as described in this bulletin, are provided for your information only and should not be relied upon unless confirmed in writing.

Please contact your local sales representative for product availability in your region. For more information visit www.spxflow.com.

The green ">" is a trademark of SPX FLOW, Inc.

ISSUED 11/2015

COPYRIGHT ©2015 SPX FLOW, Inc.